

Mini-Excavator



30V4

Motor Yanmar
 Stage IIIA
 Certificare CE
 si ISO9001

- Proiectoare montate pe brat
- Senile gumate sau metalice
- Automatizare reglari hidraulice
- Pozitie ergonomica pentru operator

- Doua viteze de translatie
- Servocomenzi hidraulice cu joystick
- Cabina inchisa cu incalzire
- Sistem auxiliar pe brat cu conectare rapida

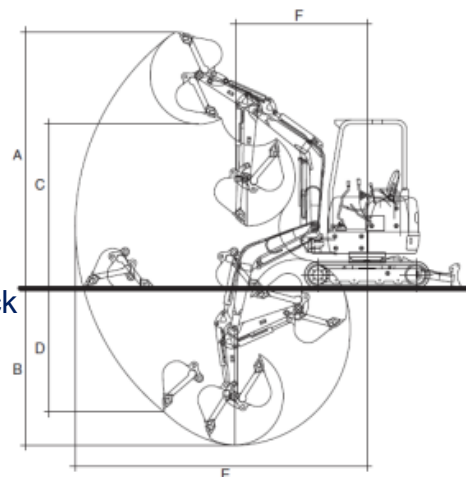

Excavator cu senile	30V4	30V4+
Tip brat	Standard	Lung
Tip motor	Yanmar 3TNV88	
Combustibil	Motorina	
Putere max. motor	23.4 cp	
Adancime max. de excavare	2700 mm	3000 mm
Lungime max. excavare	2210 mm	2470 mm
Inaltime max. descarcare	4630 mm	4720 mm
Forta excavare	2970 kgf	
Capacitate cupa	0.064 m ³	
Latime cupa	550 mm	
Ecartament	1550 mm	
Greutate cu cabina deschisa / inchisa	3030 / 3180 kg	
Greutate de operare cabina deschisa/inchisa	3105 / 3255 kg	
Dimensiuni transport (mm)	4440/1550/2480	

Dim. mm	A	B	C	D	E	F
30V4	4630	2700	3290	2210	4900	2080
30V4+	4720	3000	3390	2470	5190	2110

Dotare standard cupa excavare
 si lama nivelare

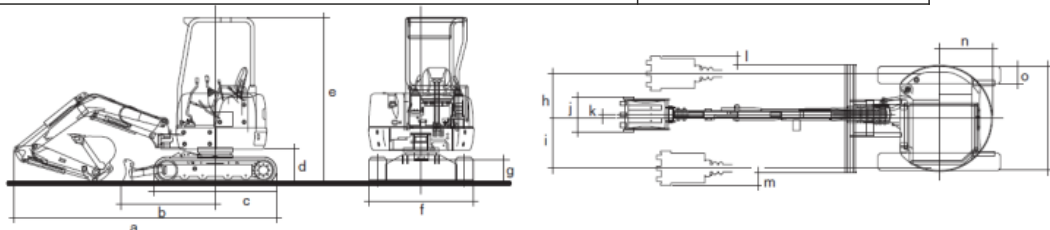

Dim. mm.	a	b	c	d	e	f	g	h	l	j	k	l	m	n	o	p
30VX	4370	1490	2100	570	2470	1550	380	510	750	550	60	200	200	775	300	1550

Calitate si fiabilitate
 la standarde Japoneze



ETOP
 creat să reziste

Republica Moldova, MD-2023
 mun. Chișinău, str. Uzinelor 90
 + /373/ 67 707 707
 office@etop.md
 www.etop.md

Mini-Excavator

30V4



Geam rabatabil
Cabina cu pana la 25% mai mare

Sistem hidraulic ce dezvolta pana la 29.7 kN forta de excavare a cupei
Optional sistem hidraulic pentru echipamentele auxiliare



Dispozitiv pentru reducerea zgomotului si a vibratiilor

Efficient in reducerea zgomotului si a vibratiilor, asigura un confort marit in cabina



Incalzire

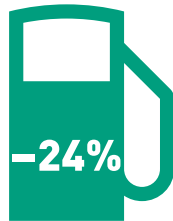

Consum redus de carburant

+20% Mai mult spatiu pentru picioare



Joystick ergonomic - Control proportional pentru sistem auxiliar
Operatiunile usoare sunt controlate printr-o valva pivotanta.

Priza si bricheta

Lama nivelare cu 2 viteze

Monitor

Optional: Cel de-al 3-lea sistem auxiliar

Cel de-al 2-lea sistem auxiliar

Joystick ergonomic

Sistem de blocare
Toate manevrele sunt oprite inclusiv: deplasarea, miscarea bratului sau a rotirii



Monitor ce afiseaza nivelul de combustibil, temperatura uleiului hidraulic, contor de ore, si alti martori



ETOP
creat să reziste

Republica Moldova, MD-2023
mun. Chișinău, str. Uzinelor 90
+ /373/ 67 707 707
office@etop.md
www.etop.md