

# Electric powered forklift 1.0 - 1.5 ton

**TRAIGO<sup>24</sup>**



# Electric powered forklifts 1.0 - 1.5 ton

Truck specifications					8FBES10T	8FBES13T	8FBES15T
Identification	1.1	Manufacturer			Toyota	Toyota	Toyota
	1.2	Model			8FBES10T	8FBES13T	8FBES15T
	1.3	Drive			electric	electric	electric
	1.4	Operator type			rider seated	rider seated	rider seated
	1.5	Load capacity/rated load	Q		1000	1250	1500
	1.6	Load centre	c		500	500	500
	1.8	Load distance, centre of drive axle to fork	x		330	330	330
	1.9	Wheelbase	y	mm	984	1146	1146
	Weight	2.1	Service weight		kg	2516	2774
2.2		Axle load, with load, front/rear		kg	2965/551	3396/628	3819/588
2.3		Axle load, without load, front/rear		kg	1098/ 1418	1209/1565	1187/1720
Tyres	3.1	Tyre - pneumatic (P), pneumatic shaped cushion (SE), solid rubber (R)			SE	SE	SE
	3.2	Tyre size, front			18x7-8	18x7-8	18x7-8
	3.3	Tyre size, rear			18x7-8	18x7-8	18x7-8
	3.5	Wheels, number front/rear (x = driven wheels)			2/1x	2 / 1x	2/1x
	3.6	Track width, front	b <sub>10</sub>	mm	837	837	837
	3.7	Track width, rear	b <sub>11</sub>	mm	0	0	0
	Dimensions	4.1	Tilt of mast/fork carriage forward/backward	$\alpha/\beta$	deg	5/6	5/6
4.2		Height, mast lowered	h <sub>1</sub>	mm	2140	2140	2140
4.3		Free lift	h <sub>2</sub>	mm	80	80	80
4.4		Lift	h <sub>3</sub>	mm	3270	3270	3270
		Lift height	h <sub>23</sub>	mm	3305	3305	3305
4.5		Height, mast extended	h <sub>4</sub>	mm	3820	3820	3820
4.7		Height of overhead guard (cab)	h <sub>6</sub>	mm	2055	2055	2055
4.8		Seat height	h <sub>7</sub>	mm	1032	1032	1032
4.12		Coupling height	h <sub>10</sub>	mm	621	621	621
4.19		Overall length	l <sub>1</sub>	mm	2359	2521	2550
4.20		Length to face of forks	l <sub>2</sub>	mm	1559	1721	1750
4.21		Overall width	b <sub>1</sub>	mm	990	990	990
4.22		Fork dimensions	s/e/l	mm	35x100x800	35x100x800	35x100x800
4.23		Fork carriage DIN 15 173, class/type A, B			II A	II A	II A
4.24		Fork-carriage width	b <sub>3</sub>	mm	920	920	920
4.31		Ground clearance, with load, below mast	m <sub>1</sub>	mm	90	90	90
4.32		Ground clearance, centre of wheelbase	m <sub>2</sub>	mm	91,5	91,5	91,5
4.33		Aisle width for pallets 1000x1200 crossways	A <sub>st</sub>	mm	2888	3050	3079
4.34		Aisle width for pallets 800x1200 lengthways	A <sub>st</sub>	mm	3010	3172	3201
4.35		Turning radius	W <sub>a</sub>	mm	1229	1391	1420
4.36	Internal turning radius	b <sub>13</sub>	mm	0	-	-	
Performance data	5.1	Travel speed, with/without load		km/h	12,0/12,5	12,0/12,5	12,0/12,5
	5.2	Lift speed, with/without load		m/s	0,34/0,52	0,32/0,52	0,31/0,52
	5.3	Lowering speed, with/without load		m/s	0,59/0,50	0,59/0,50	0,59/0,50
	5.5	Drawbar pull, with/without load		N	1470/1670	1420/1670	1370/1670
	5.6	Max. drawbar pull, with/without load		N	7400/7600	7300/7600	7300/7600
	5.7	Gradeability, with/without load		%	8/12	7/11	6/11
	5.8	Max. gradeability, with/without load		%	17/25	16/25	16/25
	5.9	Acceleration time, with/without load		s	5,8/5,2	5,9/5,3	5,9/5,3
	5.10	Service brake			hydraulic	hydraulic	hydraulic
	Electric motor	6.1	Drive motor rating S2 60 min		kW	6	6
6.2		Lift motor rating S3 15%		kW	11	11	11
6.3		Battery acc. to DIN 43 531/35/36 A, B, C, no			DIN 43535 A	DIN 43535 A	DIN 43535 A
6.4		Battery voltage, nominal capacity K <sub>s</sub>		V/Ah	24/420-500	24 / 735-875	24 / 735-875
6.5		Battery weight		kg	372	600	600
6.6		Energy consumption acc. to EN16796:2016		kWh/h	2.2	2.6	2,7
Other	8.1	Type of drive control			inverter MOSFET	inverter MOSFET	inverter MOSFET
	8.2	Operating pressure for attachments		bar	130/160	130/160	130/160
	8.3	Oil volume for attachments		l/min	-	-	-
	8.4	Sound level at the driver's ear according to EN 12 053		dB(A)	62,4	62,4	62,4

All data are based on table configuration. Other configurations may give other values.

Truck performance and dimensions are nominal and subject to tolerances.

Products and specifications are subject to change without notice.

# Mast dimensions and rated capacities

Model			V							FV, FW					FSV, FSW					
8FBES10T, 8FBES13T, 8FBES15T	Lift height	$h_{23}$	3005	3305	3505	3705	4005	4505	5005	3005	3305	3505	3705	4005	4315	4705	5005	5505	6005	6505
	Lift	$h_3$	2970	3270	3470	3670	3970	4470	4970	2970	3270	3470	3670	3970	4280	4670	4970	5470	5970	6470
	Height, mast lowered	$h_1$	1990	2140	2240	2340	2490	2740	3090	1990	2140	2240	2340	2490	1975	2090	2190	2390	2540	2740
	Height, mast extended <sup>1)</sup>	$h_4$	3520	3820	4020	4220	4520	5020	5535	3520	3820	4020	4220	4520	4830	5220	5520	6020	6520	7020
	Height, mast extended <sup>2)</sup>	$h_4$	4090	4390	4590	4790	5090	5590	6090	4090	4390	4590	4790	5090	5400	5790	6090	6590	7090	7590
	Free lift, without load backrest	$h_2$	80	80	80	80	80	80	80	1445	1595	1695	1795	1945	1430	1545	1645	1845	1995	2195
	Free lift, with load backrest	$h_2$	80	80	80	80	80	80	80	870	1020	1120	1220	1370	855	970	1070	1270	1420	1620

1) Without load backrest

2) With load backrest; Height of standard load backrest is 1120 mm.

Pneumatic shaped cushion/cushion tyre			V							FV, FW					FSV, FSW					
8FBES10T	Tilt range, forward	deg	5	5	5	5	5	5	5	5	5	5	5	5	5	5	5	5	5	5
	Tilt range, backward	deg	6	6	6	6	6	6	6	6	6	6	6	6	6	6	6	4	4	4
	Load capacity at 500 mm LC	kg	1000	1000	1000	1000	1000	1000	1000	1000	1000	1000	1000	1000	1000	1000	1000	970	930	650
8FBES13T	Tilt range, forward	deg	5	5	5	5	5	5	5	5	5	5	5	5	5	5	5	5	5	5
	Tilt range, backward	deg	6	6	6	6	6	6	6	6	6	6	6	6	6	6	6	4	4	4
	Load capacity at 500 mm LC	kg	1250	1250	1250	1250	1250	1250	1250	1250	1250	1250	1250	1250	1250	1250	1250	1250	1050	800
8FBES15T	Tilt range, forward	deg	5	5	5	5	5	5	5	5	5	5	5	5	5	5	5	5	5	5
	Tilt range, backward	deg	6	6	6	6	6	6	6	6	6	6	6	6	6	6	6	4	4	4
	Load capacity at 500 mm LC	kg	1500	1500	1500	1500	1500	1500	1430	1500	1500	1500	1500	1500	1500	1480	1430	1330	1150	800

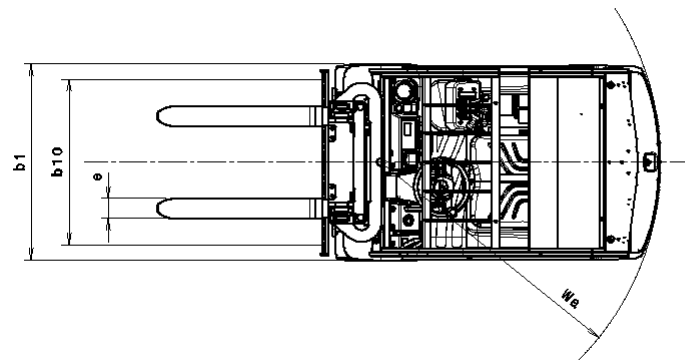
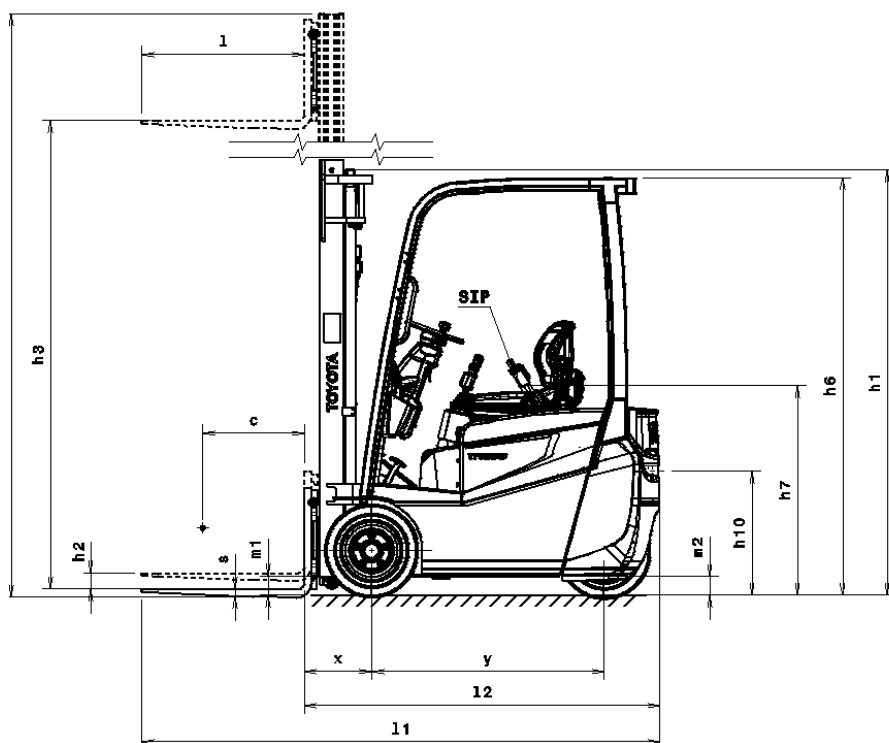

## Standard equipments:

- Toyota SAS (System of Active Stability) incl. speed reduction when cornering
- Toyota AC power system
- Toyota OPS (Operator Presence Sensing)
- Wide visibility mast (MFH: 3270 mm)
- Long forks (Length: 800 mm)
- Long forkbar (Length: 920 mm)
- 3-way valve
- Pneumatic shaped cushion tyres
- Full hydraulic power steering
- Multifunction display
- Memory tilt steering column
- Emergency button
- Assist grip
- Shockless landing lift



**ETOP**  
creat să reziste

Republica Moldova, MD-2023  
mun. Chişinău, str. Uzinelor 90  
+ /373/ 67 707 707  
office@etop.md  
[www.etop.md](http://www.etop.md)

**TOYOTA**

MATERIAL HANDLING