

# ARX 26-2C

## LIGHT TANDEM VIBRATORY ROLLER

EU Stage V / U.S. EPA Tier 4f



### WORKING AROUND OBSTRUCTIONS

The Ammann ARX 26-2C Light Tandem Roller makes it easier to see – and work – near obstructions. It also offers a drum in front and tyres in back to provide both compaction power and the sealing effect of pneumatic rollers. The roller features a new articulation joint that enables quick drum adjustment from in-line to offset configurations, helpful when working close to obstructions. Operators need watch only one drum, knowing the second will be a safe distance from the obstacle. The in-line drum setting is available when it's time for productivity in open spaces.

### APPLICATIONS

- Small and medium construction sites
- City roads
- Boardwalks
- City street repairs
- Road maintenance

### PRODUCTIVITY

#### Electronic drive lever

Advanced drive control enables smooth starts and stops during machine operation.

#### Articulation joint with oscillation

Great manoeuvrability and constant contact with the surface are key factors in achieving high quality compaction.

#### Sprinkling system

Multi-level filtration system with large water tank for extended intervals between fillings.

### ERGONOMICS

#### Operator platform design

Spacious operator platform with comfortable driver's seat.

#### Simple & convenient operation control

Dashboard with clear display and intuitive machine control.

#### Exceptional operator visibility

Perfect all-around machine visibility to maximise safety on the jobsite.

### SERVICEABILITY

#### Tool-free daily inspection

Quick and easy daily inspection.

#### Maintenance-free parts

Reduce time required for machine maintenance and prevent damage to components.

#### Service point locations

Service and regular maintenance points are quickly and readily accessible.

MAXIMUM RECOMMENDED COMPACTED LIFT THICKNESS AT OPTIMAL WORKING CONDITIONS

	Sand / gravel	Mixed soils	Silt	Clay	Stabilisation	Asphalt
ARX 26-2C	220 mm (8.7 in)	150 mm (5.9 in)	–	–	100 mm (3.9 in)	80 mm (3.2 in)

TECHNICAL SPECIFICATIONS  
ARX 26-2C COMBINATION TANDEM ROLLER  
EU Stage V / U.S. EPA Tier 4f

## DIMENSIONS

A	MACHINE LENGTH	2500 mm (98.4 in)
B	WHEELBASE	1755 mm (69.1 in)
C	MACHINE HEIGHT	2550 mm (100.4 in)
D	MACHINE HEIGHT (FOLDED ROPS)	1935 mm (76.2 in)
E	DRUM WIDTH	1200 mm (47.2 in)
G	MACHINE LENGTH	2585 mm (101.8 in)
H	GROUND CLEARANCE	280 mm (11 in)
H1	SIDE CLEARANCE	490 mm (19.3 in)
I	DRUM DIAMETER	695 / 635 mm (27.4 / 25 in)
J	DRUM SHELL THICKNESS	13 mm (0.5 in)
K	MACHINE WIDTH (TOTAL)	1295 mm (51 in)

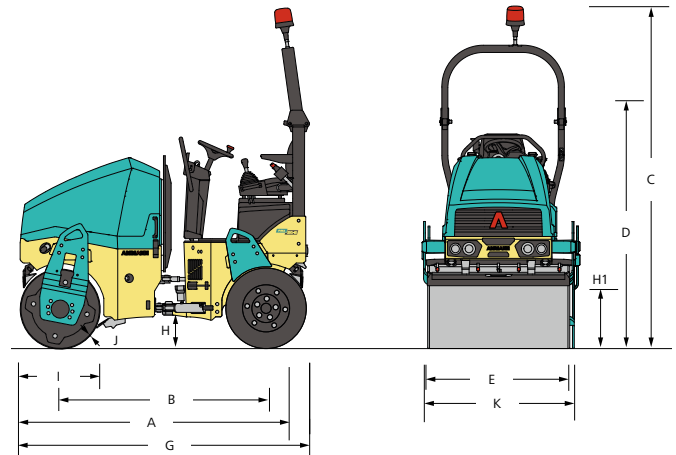

## WEIGHT & OPERATING CHARACTERISTICS

OPERATING WEIGHT CECE	2350 kg (5180 lb)
OPERATING WEIGHT MAX.	2365 kg (5210 lb)
STAT. LIN. LOAD	10.2 kg/cm (22.5 lb/in)
TURNING RADIUS INSIDE	2540 mm (100 in)
STEERING / OSCILLATING ANGLE	30/6.5 ±°

## ENGINE

ENGINE TYPE	Kubota D1803-CR
EMMISSION CLASS	EU Stage V / U.S. EPA Tier 4 Final
POWER OUTPUT ISO 3046	25 kW / 33.5 HP
CYLINDER / LTR.	3 cyl / 1826 cm <sup>3</sup>
1. / 2. WORKING SPEED	2100 / 2400 rpm
TRAVEL SPEED	11 km/h (6.8 MPH)
GRADEABILITY WITH / WITHOUT VIBR.	35% / 35%

## COMPACTION FORCES

AMPLITUDE I	0.5 mm (0.02 in)
AMPLITUDE II	0.5 mm (0.02 in)
FREQUENCY I	58 Hz (3480 vpm)
FREQUENCY II	66 Hz (3960 vpm)
CENTRIFUGAL FORCE I	38.8 kN (8722 lbf)
CENTRIFUGAL FORCE II	46.5 kN (10454 lbf)

## MISCELLANEOUS

BATTERY / CAPACITY	12/77 V/Ah
WATER TANK	190 l (50.2 gal)
ANTI-ADHESIVE TANK	12 l (3.17 gal)
HYDRAULIC TANK	28.5 l (7.5 gal)
DIESEL FUEL TANK	35 l (9.2 gal)
NUMBER OF WHEELS	4
TIRE SIZE	9.5 / 65-15

### STANDARD

- Front and rear drive / front vibration
- Pressurised pulse interval sprinkler system
- Anti-adhesive sprinkling circuit
- 2 working frequencies
- Control system with emergency stop
- Ammann Vibration Control
- Lateral sliding seat
- Hydraulic test ports
- Off-set into in-line drum setting
- Battery disconnection switch
- On-board diagnostics
- Front/rear rubber bumpers

### OPTIONAL EQUIPMENT

- CE-kit with folding ROPS and working lights
- Road lights
- Infrared thermometer
- ACE<sup>force</sup>
- ATC - Ammann Traction Control
- Reverse alarm
- Additional working lights (ROPS mounted)
- Warning beacon
- Second drive-lever, left
- Arm rests
- Edge-cutter inc. Multi-function lever
- Scrapers tiltable
- Bio-degradable hydraulic oil
- Central lifting point
- Customer color
- Weather canopy
- Servicelink