

ARX 26.1-2

LIGHT TANDEM VIBRATORY ROLLER
EU Stage V / U.S. EPA Tier 4 final



WORKING AROUND OBSTRUCTIONS

The Ammann ARX 26.1-2 Tandem Roller is a great fit for the rental market and contractors looking for a low-maintenance machine with an intuitive dashboard and controls.

The roller features a maintenance free articulation joint that enables quick drum adjustment from in-line to off-set configurations, helpful when working close to obstructions. The in-line drum setting is available when it's time for productivity in open spaces.

The roller utilises a Kubota / Yanmar engine that meets EU Stage V and U.S. EPA T4f emission standards.

APPLICATIONS

- Small and medium construction sites
- City roads
- Boardwalks
- City street repairs
- Road maintenance

PRODUCTIVITY

Electronic drive lever

Advanced drive control enables smooth starts and stops during machine operation.

Articulation joint with oscillation

Great manoeuvrability and constant contact with the surface are key factors in achieving high quality compaction.

Sprinkling system

Multi-level filtration system with large water tank for extended intervals between fillings.

ERGONOMICS

Operator platform design

Spacious operator platform with comfortable driver's seat.

Simple & convenient operation control

Dashboard with clear display and intuitive machine control.

Exceptional operator visibility

Perfect all-around machine visibility to maximise safety on the jobsite.

SERVICEABILITY

Tool-free daily inspection

Quick and easy daily inspection.

Maintenance-free parts

Reduce time required for machine maintenance and prevent damage to components.

Service point locations

Service and regular maintenance points are quickly and readily accessible.

MAXIMUM RECOMMENDED COMPACTED LIFT THICKNESS AT OPTIMAL WORKING CONDITIONS

	Sand / gravel	Mixed soils	Silt	Clay	Stabilisation	Asphalt
ARX 26.1-2	250 mm (9.8 in)	180 mm (7.1 in)	-	-	120 mm (4.7 in)	100 mm (3.9 in)

TECHNICAL SPECIFICATIONS
ARX 26.1-2 TANDEM ROLLER
EU Stage V / U.S. EPA Tier 4 final

DIMENSIONS

A	MACHINE LENGTH	2500 mm (98.4 in)
B	WHEELBASE	1740 mm (68.5 in)
C	MACHINE HEIGHT	2550 mm (100.4 in)
D	MACHINE HEIGHT (FOLDED ROPS)	1935 mm (76.2 in)
E	DRUM WIDTH	1200 mm (47.2 in)
F	WORKING WIDTH WITH OFFSET	1240 mm (48.8 in)
G	MACHINE LENGTH (FOLDED ROPS)	2585 mm (101.8 in)
H	GROUND CLEARANCE	280 mm (11 in)
H1	SIDE CLEARANCE	490 mm (19.3 in)
I	DRUM DIAMETER	695 mm (27.4 in)
J	DRUM SHELL THICKNESS	13 mm (0.5 in)
K	MACHINE WIDTH (TOTAL)	1350 mm (53.1 in)

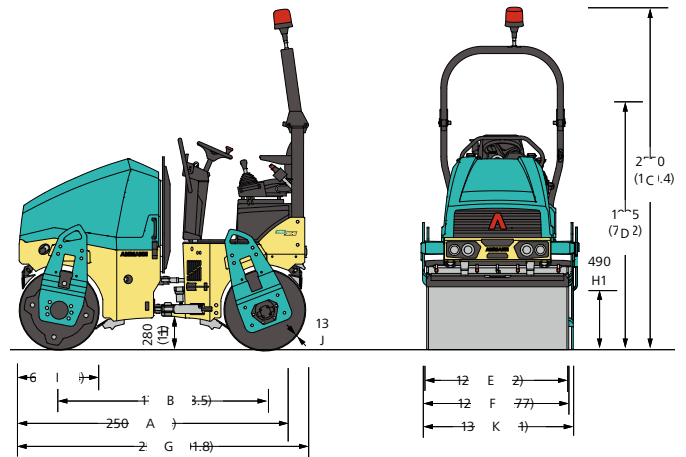

WEIGHT AND OPERATING CHARACTERISTICS

OPERATING WEIGHT CECE	2460 kg (5423 lb)
OPERATING WEIGHT MAX.	2655 kg (5853 lb)
STAT. LIN. LOAD OF FRONT DRUM	9.8 kg/cm (21.6 lb/in)
STAT. LIN. LOAD OF REAR DRUM	10.7 kg/cm (23.6 lb/in)
TURNING RADIUS INSIDE	2540 mm (100 in)
STEERING / OSCILLATING ANGLE	30/6.5 ±°
DRUM OFFSET	40 mm (1.57 in)

ENGINE

ENGINE TYPE	Kubota D1703-M-DI	Yanmar 3TNV88F-EPAMM
EMMISSION CLASS	EU Stage V / U.S. EPA Tier 4 Final	
POWER OUTPUT ISO 3046	18.5 kW (24.8 HP)	
CYLINDER / LTR.	3 cyl / 1826 cm ³	
NOMINAL SPEED	2100 / 2400 rpm	
TRAVEL SPEED	10 km/h (6.2 MPH)	
GRADEABILITY WITH / WITHOUT VIBR.	25% / 30%	

COMPACTION FORCES

AMPLITUDE I	0.5 mm (0.02 in)
AMPLITUDE II	0.5 mm (0.02 in)
FREQUENCY I	58 Hz (3480 vpm)
FREQUENCY II	66 Hz (3960 vpm)
CENTRIFUGAL FORCE I	36.4 kN (8183 lbf)
CENTRIFUGAL FORCE II	42.8 kN (9622 lbf)

MISCELLANEOUS

BATTERY / CAPACITY	12/77 V/Ah
WATER TANK	190 l (50.2 gal)
HYDRAULIC TANK	28.5 l (7.5 gal)
DIESEL FUEL TANK	35 l (9.2 gal)

STANDARD

- Front and rear vibration & drive
- Pressurised pulse interval sprinkler system
- 2 working frequencies
- Control system with emergency stop
- Ammann Vibration Control
- Lateral sliding seat
- Hydraulic test ports
- Off-set into in-line drum setting
- Battery disconnection switch
- On-board diagnostics
- Front/rear rubber bumpers

OPTIONAL EQUIPMENT

- CE-kit with folding ROPS and working lights
- Road lights
- Infrared thermometer
- ACE^{force}
- ATC - Ammann Traction Control
- Reverse alarm
- Additional working lights (ROPS mounted)
- Warning beacon
- Second drive-lever, left
- Arm rests
- Edge-cutter inc. Multi-function lever
- Scrapers tiltable
- Bio-degradable hydraulic oil
- Central lifting point
- Customer color
- Weather canopy
- Servicelink