

ARX 26.1-2C

LIGHT TANDEM VIBRATORY ROLLER

EU Stage V / U.S. EPA Tier 4 final



WORKING AROUND OBSTRUCTIONS

The Ammann ARX 26.1-2C Tandem Roller is a great fit for the rental market and contractors looking for a low-maintenance machine with an intuitive dashboard and controls.

It is also a combination roller, with a drum in front and four pneumatic tyres in the rear. The combination feature provides a number of added benefits. The tyres provide a kneading effect, helpful on certain types of asphalt mixes and temperatures. The roller utilises a Kubota / Yanmar engine that meets EU Stage V and U.S. EPA T4f emission standards.

APPLICATIONS

- Small and medium construction sites
- City roads
- Boardwalks
- City street repairs
- Road maintenance

PRODUCTIVITY

Electronic drive lever

Advanced drive control enables smooth starts and stops during machine operation.

Articulation joint with oscillation

Great manoeuvrability and constant contact with the surface are key factors in achieving high quality compaction.

Sprinkling system

Multi-level filtration system with large water tank for extended intervals between fillings.

ERGONOMICS

Operator platform design

Spacious operator platform with comfortable driver's seat.

Simple & convenient operation control

Dashboard with clear display and intuitive machine control.

Exceptional operator visibility

Perfect all-around machine visibility to maximise safety on the jobsite.

SERVICEABILITY

Tool-free daily inspection

Quick and easy daily inspection.

Maintenance-free parts

Reduce time required for machine maintenance and prevent damage to components.

Service point locations

Service and regular maintenance points are quickly and readily accessible.

MAXIMUM RECOMMENDED COMPACTED LIFT THICKNESS AT OPTIMAL WORKING CONDITIONS

| | Sand / gravel | Mixed soils | Silt | Clay | Stabilisation | Asphalt |
|-------------|-----------------|-----------------|------|------|-----------------|----------------|
| ARX 26.1-2C | 220 mm (8.7 in) | 150 mm (5.9 in) | - | - | 100 mm (3.9 in) | 80 mm (3.2 in) |

TECHNICAL SPECIFICATIONS
ARX 26.1-2C COMBINATION TANDEM ROLLER
EU Stage V / U.S. EPA Tier 4f

DIMENSIONS

| | | |
|----|------------------------------|-----------------------------|
| A | MACHINE LENGTH | 2500 mm (98.4 in) |
| B | WHEELBASE | 1755 mm (69.1 in) |
| C | MACHINE HEIGHT | 2550 mm (100.4 in) |
| D | MACHINE HEIGHT (FOLDED ROPS) | 1935 mm (76.2 in) |
| E | DRUM WIDTH | 1200 mm (47.2 in) |
| G | MACHINE LENGTH | 2585 mm (101.8 in) |
| H | GROUND CLEARANCE | 280 mm (11 in) |
| H1 | SIDE CLEARANCE | 490 mm (19.3 in) |
| I | DRUM DIAMETER | 695 / 635 mm (27.4 / 25 in) |
| J | DRUM SHELL THICKNESS | 13 mm (0.5 in) |
| K | MACHINE WIDTH (TOTAL) | 1295 mm (51 in) |

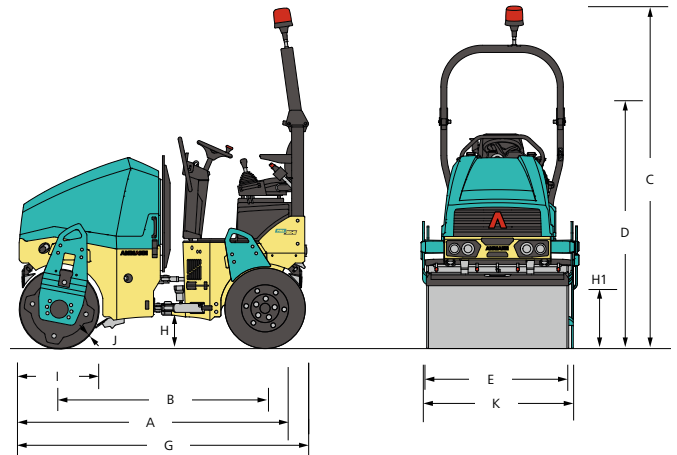

WEIGHT & OPERATING CHARACTERISTICS

| | |
|------------------------------|------------------------|
| OPERATING WEIGHT CECE | 2300 kg (5071 lb) |
| OPERATING WEIGHT MAX. | 2500 kg (5510 lb) |
| STAT. LIN. LOAD | 9.8 kg/cm (21.6 lb/in) |
| TURNING RADIUS INSIDE | 2540 mm (100 in) |
| STEERING / OSCILLATING ANGLE | 30/6.5 ±° |

COMPACTION FORCES

| | |
|----------------------|--------------------|
| AMPLITUDE I | 0.5 mm (0.02 in) |
| AMPLITUDE II | 0.5 mm (0.02 in) |
| FREQUENCY I | 58 Hz (3480 vpm) |
| FREQUENCY II | 66 Hz (3960 vpm) |
| CENTRIFUGAL FORCE I | 36.4 kN (8183 lbf) |
| CENTRIFUGAL FORCE II | 42.8 kN (9622 lbf) |

ENGINE

| ENGINE TYPE | Kubota | Yanmar |
|-----------------------------------|------------------------------------|---------------|
| | D1703-M-DI | 3TNV88F-EPAMM |
| EMMISSION CLASS | EU Stage V / U.S. EPA Tier 4 Final | |
| POWER OUTPUT ISO 3046 | 18.5 kW (24.8 HP) | |
| CYLINDER / LTR. | 3 cyl / 1826 cm ³ | |
| NOMINAL SPEED | 2100 / 2400 rpm | |
| TRAVEL SPEED | 10 km/h (6.2 MPH) | |
| GRADEABILITY WITH / WITHOUT VIBR. | 25% / 30% | |

MISCELLANEOUS

| | |
|--------------------|------------------|
| BATTERY / CAPACITY | 12/77 V/Ah |
| WATER TANK | 190 l (50.2 gal) |
| ANTI-ADHESIVE TANK | 12 l (3.17 gal) |
| HYDRAULIC TANK | 28.5 l (7.5 gal) |
| DIESEL FUEL TANK | 35 l (9.2 gal) |
| WHEEL LOAD | 280 kg (573 lb) |
| NUMBER OF WHEELS | 4 |
| TIRE SIZE | 9.5 / 65-15 |

STANDARD

- Front and rear drive / front vibration
- Pressurised pulse interval sprinkler system
- Anti-adhesive sprinkling circuit
- 2 working frequencies
- Control system with emergency stop
- Ammann Vibration Control
- Lateral sliding seat
- Hydraulic test ports
- Off-set into in-line drum setting
- Battery disconnection switch
- On-board diagnostics
- Front/rear rubber bumpers

OPTIONAL EQUIPMENT

- CE-kit with folding ROPS and working lights
- Road lights
- Infrared thermometer
- ACE^{force}
- ATC - Ammann Traction Control
- Reverse alarm
- Additional working lights (ROPS mounted)
- Warning beacon
- Second drive-lever, left
- Arm rests
- Edge-cutter inc. Multi-function lever
- Scrapers tiltable
- Bio-degradable hydraulic oil
- Central lifting point
- Customer color
- Weather canopy
- Servicelink