

ARX 36-2

LIGHT TANDEM VIBRATORY ROLLER

EU Stage V / U.S. EPA Tier 4 Final



AVOIDING OBSTRUCTIONS

The Ammann ARX 36-2 Light Tandem Roller makes it easier to see – and work – near obstructions. The roller features a new articulating joint that enables quick drum adjustment from in-line to offset configurations, helpful when working close to obstructions. Operators need watch only one drum, knowing the second will be a safe distance from the obstacle. The in-line drum setting is available when it's time for productivity in open spaces.

APPLICATIONS

- Small and medium construction sites
- City roads
- Boardwalks
- City street repairs
- Road maintenance

PRODUCTIVITY

Electronic drive lever

Advanced drive control enables smooth starts and stops during machine operation.

Articulation joint with oscillation

Great manoeuvrability and constant contact with the surface are key factors in achieving high quality compaction.

Sprinkling system

Multi-level filtration system with large water tank for extended intervals between fillings.

ERGONOMICS

Operator platform design

Spacious operator platform with comfortable driver's seat.

Simple & convenient operation control

Dashboard with clear display and intuitive machine control.

Exceptional operator visibility

Perfect all-around machine visibility to maximise safety on the jobsite.

SERVICEABILITY

Tool-free daily inspection

Quick and easy daily inspection.

Maintenance-free parts

Reduce time required for machine maintenance and prevent damage to components.

Service point locations

Service and regular maintenance points are quickly and readily accessible.

MAXIMUM RECOMMENDED COMPACTED LIFT THICKNESS AT OPTIMAL WORKING CONDITIONS

	Sand / gravel	Mixed soils	Silt	Clay	Stabilisation	Asphalt
ARX 36-2	300 mm (11.8 in)	200 mm (7.9 in)	–	–	150 mm (5.9 in)	120 mm (4.7 in)

TECHNICAL SPECIFICATIONS
ARX 36-2 LIGHT TANDEM VIBRATORY ROLLER
EU Stage V / U.S. EPA Tier 4 Final

DIMENSIONS

A	MACHINE LENGTH	2915 mm (114.8 in)
B	WHEELBASE	1950 mm (76.8 in)
C	MACHINE HEIGHT	2840 mm (111.8 in)
D	MACHINE HEIGHT (FOLDED ROPS)	2150 mm (84.6 in)
E	DRUM WIDTH	1300 mm (51.2 in)
F	WORKING WIDTH WITH OFFSET	1340 mm (52.8 in)
G	MACHINE LENGTH (FOLDED ROPS)	3000 mm (118.1 in)
H	GROUND CLEARANCE	330 mm (13 in)
H1	SIDE CLEARANCE	605 mm (23.8 in)
I	DRUM DIAMETER	850 mm (33.5 in)
J	DRUM SHELL THICKNESS	18 mm (0.7 in)
K	MACHINE WIDTH (TOTAL)	1385 mm (54.5 in)

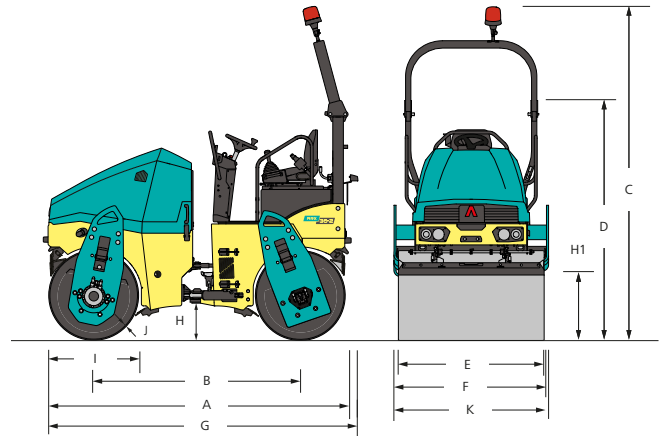

WEIGHT AND OPERATING CHARACTERISTICS

OPERATING WEIGHT CECE	3785 kg (8344 lb)
OPERATING WEIGHT MAX.	4075 kg (8984 lb)
STAT. LIN. LOAD OF FRONT DRUM	14.1 kg/cm (31 lb)
STAT. LIN. LOAD OF REAR DRUM	16.5 kg/cm (36 lb)
TURNING RADIUS INSIDE	2830 mm (111.4 in)
STEERING / OSCILLATING ANGLE	35/9 ±°
DRUM OFFSET	40 mm (1.6 in)

ENGINE

ENGINE TYPE	Kubota D1803-CR-T
EMMISSION CLASS	EU Stage V / U.S. EPA Tier 4 Final
POWER OUTPUT ISO 3046	32.8 kW (44 HP)
CYLINDER / LTR.	3 cyl / 1826 cm ³
NOMINAL SPEED	2400 rpm
TRAVEL SPEED	10 km/h (6.2 MPH)
GRADEABILITY WITH / WITHOUT VIBR.	30 % / 40 %

COMPACTION FORCES

AMPLITUDE I	0.4 mm (0.016 in)
AMPLITUDE II	0.6 mm (0.024 in)
FREQUENCY I	41 Hz (2460 VPM)
FREQUENCY II	55 Hz (3300 VPM)
CENTRIFUGAL FORCE I	39.3 kN (8835 lbf)
CENTRIFUGAL FORCE II	50.7 kN (11 397.8 lbf)
CENTRIFUGAL FORCE III	51.9 kN (11 667.6 lbf)

MISCELLANEOUS

BATTERY / CAPACITY	12/77 V/Ah
WATER TANK	340 l (89.8 gal)
HYDRAULIC TANK	53.5 l (14.1 gal)
DIESEL FUEL TANK	57 l (15.1 gal)

STANDARD

- Front and rear vibration & drive
- Pressurised pulse interval sprinkler system
- 2 stage vibratory system
- Control system with emergency stop
- Ammann Vibration Control
- Lateral sliding seat
- Hydraulic test ports
- Off-set into in-line drum setting
- Battery disconnection switch
- On-board diagnostics
- Front/rear rubber bumpers

OPTIONAL EQUIPMENT

- CE-kit with folding ROPS and working lights
- Road lights
- Infrared thermometer
- ACE^{force}
- ATC - Ammann Traction Control
- Reverse alarm
- Additional working lights (ROPS mounted)
- Warning beacon
- Second drive-lever, left
- Arm rests
- Edge-cutter inc. Multi-function lever
- Scrapers tiltable
- Bio-degradable hydraulic oil
- Customer color
- Wheather canopy
- Servicelink