

# ARS 220

## SOIL COMPACTOR

EU Stage V / U.S. EPA Tier 4 Final

### COMPACTION OUTPUT LEADER

Ammann provides industry-leading compaction output while defining new highest standards in efficiency and cost saving through the ARS 220 Soil Compactor.

The machines meet EU Stage V / U.S. EPA Tier 4 Final standards and provide the cleanest and most efficient propulsion. The machines also meet the highest operator standards, with intuitive control via a centralized multifunctional display built into the steering wheel. A wide range of compaction tools such as the ACE<sup>force</sup> system help operators monitor indications of compaction.

### APPLICATIONS

- Airports runways
- Industrial zones
- Dumpsite construction

### PRODUCTIVITY

- High compaction output - faster compaction of thicker layers in fewer passes
- No-rear-axle concept – optimal stability and low center of gravity, which significantly improves safety on jobsites
- Variable range of vibration frequencies for added versatility
- ACE<sup>force</sup> Intelligent Compaction tool for higher compaction efficiency

### ERGONOMICS

- Spacious, quiet cab with integrated ROPS structure
- New multifunctional display for intuitive machine control and operation
- Excellent machine visibility with 360° view to machine edges and surroundings
- Innovative travel lever with speed adjustment and wider machine speed range (newly 5+1 speed instead of 3+1)

### SERVICEABILITY

- All service points and engine compartment accessible from the ground
- Wide-opening rear hood for easy and fast daily maintenance
- Tilttable cab for exceptional access to main hydraulic components, which significantly reduces labour
- ECOdrop – machine efficiency and reductions in fuel consumption and required fluids

#### MAXIMUM RECOMMENDED COMPACTED LIFT THICKNESS AT OPTIMAL WORKING CONDITIONS

	Rockfill	Sand / Gravel	Mixed Soils	Silt	Clay
ARS 220	1850 mm (72.8 in)	1150 mm (45.3 in)	950 mm (37.4 in)	750 mm (29.5 in)	400 mm (15.8 in)



**ETOP**  
creat să reziste

Republica Moldova, MD-2023  
mun. Chişinău, str. Uzinelor 90  
+ /373/ 67 707 707  
office@etop.md  
www.etop.md

TECHNICAL SPECIFICATIONS  
ARS 220 SOIL COMPACTOR  
EU Stage V / U.S. EPA Tier 4 Final

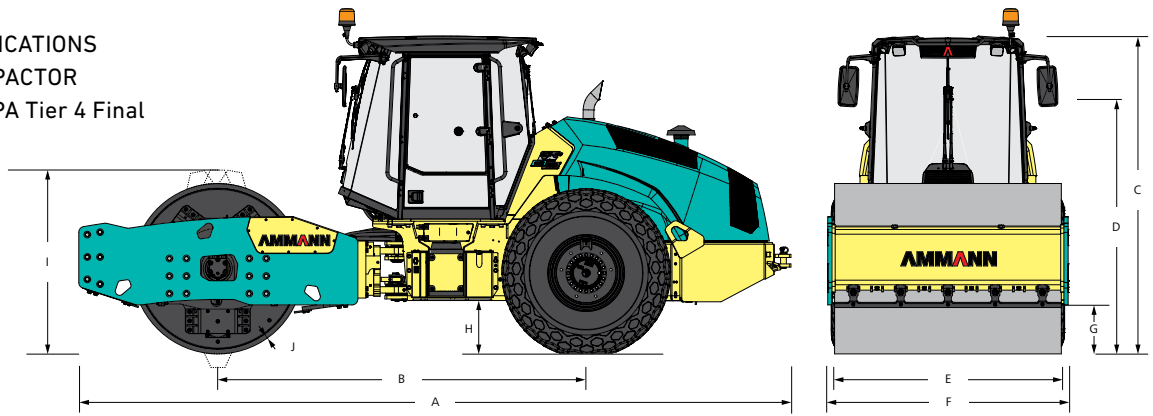

**DIMENSIONS**

A	MACHINE LENGTH	6738 mm (265 in)
B	WHEELBASE	3510 mm (138.2 in)
C	MACHINE HEIGHT	2950 mm (116.1 in)
D	MACHINE HEIGHT (OPERATOR SEAT)	2250 mm (88.6 in)
E	DRUM WIDTH	2130 mm (83.9 in)
F	MACHINE WIDTH	2300 mm (90.6 in)
G	CURB CLEARANCE	460 mm (18.1 in)
H	GROUND CLEARANCE	500 mm (19.7 in)
I	DRUM DIAMETER	1600 mm (63 in) / *1795 mm (70.7 in)
J	DRUM THICKNESS	45 mm (1.8 in) / *30 mm (1.2 in)

\*PD

**ENGINE**

MANUFACTURER	DEUTZ TCD 6.1 L6
POWER ACCORDING TO ISO 14396	160 kW (215 HP)/2300 rpm
EXHAUST GAS AFTER-TREATMENT	EGR+DOC+DPF+SCR
	EU Stage V / U.S. EPA Tier 4f

**COMPACTION FORCES**

		PD
FREQUENCY I	23–27 Hz (1380–1620 vpm)	23–27 Hz (1380–1620 vpm)
FREQUENCY II	30–34 Hz (1800–2040 vpm)	30–34 Hz (1800–2040 vpm)
AMPLITUDE I	2 mm (0.079 in)	2 mm (0.079 in)
AMPLITUDE II	1 mm (0.039 in)	1 mm (0.039 in)
CENTRIFUGAL FORCE I	275–375 kN (61,822–84,303 lbf)	275–375 kN (61,822–84,303 lbf)
CENTRIFUGAL FORCE II	233–300 kN (58,380–67,443 lbf)	233–300 kN (58,380–67,443 lbf)

**MISCELLANEOUS**

BRAKES OPERATING	Hydrostatic
BRAKES PARKING	Multiple-discspring brake
BRAKES EMERGENCY	Multiple-discspring brake
FUEL TANK CAPACITY	350 l (92.4 gal)
ARTICULATION ANGLE	±36°
OSCILLATION ANGLE	±10°

**WEIGHT & OPERATING CHARACTERISTICS**

	HX	PD	HXPD
OPERATING WEIGHT	21 930 kg (48,350 lb)	21 930 kg (48,350 lb)	22 060 kg (48,630 lb)
MAXIMUM WEIGHT	25 360 kg (55,910 lb)	25 360 kg (55,910 lb)	23 170 kg (51,080 lb)
STATIC LINEAR LOAD	66.9 kg/cm (374.6 lb/in)	66.9 kg/cm (374.6 lb/in)	-
PAD CONTACT SURFACE	-	-	143 cm <sup>2</sup> (22.2 sq in)
PAD HEIGHT	-	-	120 kg (4,7 lb)
MAX. TRANSPORT SPEED	12 km/h (7.46 mph)	11 km/h (6.84 mph)	12 km/h (7.46 mph)
MAX. WORKING SPEED	7 km/h (4.35 mph)	7 km/h (4.35 mph)	7 km/h (4.35 mph)
CLIMBING ABILITY WITHOUT / WITH VIBRATION	55 / 50 %	60 / 55 %	55 / 50 %
TURNING RADIUS (INNER)	4370 mm (172 in)	4370 mm (172 in)	4370 mm (172 in)

**STANDARD EQUIPMENT**

- ATC (Ammann Traction Control)
- Smooth drum
- Multiple frequencies / 2 amplitudes vibration system
- Multifunctional operator display
- Electrohydraulic cab and hood tilting
- Working lights head and rear
- Hydraulic test ports on components
- Diamond tread tires
- Telematics ready

**OPTIONAL EQUIPMENT**

- ACE<sup>force</sup>
- PD Drum (or PD Shell Kit)
- HX Drive version
- Air Condition for cab
- Radio with CD
- 360° Illumination Kit
- Ammann Toolkit
- Road lighting
- Warning beacon
- Back-up alarm
- Centralised hydraulic test ports
- Tractor tires