

AV 110 X

ARTICULATED TANDEM ROLLER

EU Stage IIIA / U.S. EPA Tier 3



EFFICIENT COMPACTION

A unique propulsion system powers the Ammann AV 110 X EU Stage IIIA / U.S. EPA Tier 3 Articulated Tandem Roller, helping it efficiently deliver the weight and vibration necessary to achieve optimum compaction results. Key to the propulsion system is the location of the power train in the rear frame and in independent pumps for drive and vibration. A combination of drum dimensions, frequencies and amplitudes also help deliver the desired results.

PRODUCTIVITY

Superior compaction performance

The powerful vibratory system generates high compaction forces for fast and thorough compaction

Articulated joint with oscillation

Permanent contact with the surface and a wide range of working widths for higher productivity

Sprinkling system

3-stage filtration system with large water tank for extended intervals between fillings

ERGONOMICS

A comfortable workplace

Ergonomic operator station designed for high operator comfort

Simple and reliable dashboard

Intuitive machine control, even for unskilled operators

Visibility

Excellent all-around machine visibility for jobsite safety

SERVICEABILITY

Accessible engine compartment

Tool-free, wide-opening engine hood / doors

Easy-to-reach maintenance points

All service points are optimally positioned for easy service

Self-diagnostic system

The on-board, automated diagnostic system quickly identifies potential problems

APPLICATIONS

- Medium and large jobsites
- Transport construction (motorways, railways, airfields)
- Building construction (industrial zones, harbours)

MAXIMUM RECOMMENDED COMPACTED LIFT THICKNESS AT OPTIMAL WORKING CONDITIONS

	Sand / Gravel	Mixed Soils	Silt	Clay	Stabilisation
AV 110 X	0.42 m (17 in)	0.32 m (13 in)	-	-	0.22 m (9 in)

TECHNICAL SPECIFICATIONS
 AV 110 X ARTICULATED TANDEM ROLLER
 EU Stage IIIA / U.S. EPA Tier 3

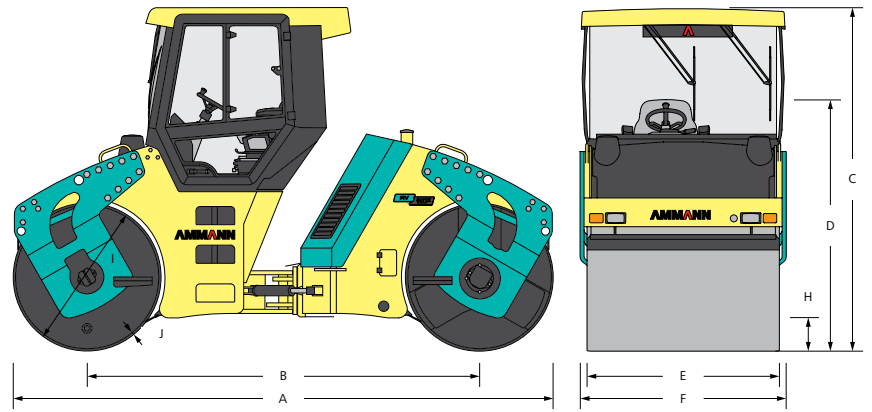

DIMENSIONS		
A	Machine length	4760 mm (187.4 in)
B	Wheelbase	3460 mm (136.2 in)
C	Machine height	3020 mm (118.9 in)
D	Machine Height (removed CAB / ROPS)	2350 mm (92.5 in)
E	Drum width	1700 mm (66.9 in)
F	Machine width	1822 mm (71.7 in)
H	Ground clearance	310 mm (12.2 in)
I	Drum diameter	1300 mm (51.2 in)
J	Drum shell thickness	22 mm (0.9 in)

COMPACTION FORCES	
Frequency I	45 Hz (2700 VPM)
Frequency II	55 Hz (3300 VPM)
Amplitude I	0.7 mm (0.028 in)
Amplitude II	0.35 mm (0.014 in)
Centrifugal force I	110 kN (24 729 lbf)
Centrifugal force II	77/83 kN (17 310/18 659 lbf)

MISCELLANEOUS	
Brakes operating	Hydrostatic
Brakes parking	Mechanical multiple-disc
Brakes emergency	Mechanical multiple-disc
Fuel tank capacity	208 l (54.9 gal)
Voltage	12 V

ENGINE	
Manufacturer	Cummins QSB3.3-C99
Power according to ISO 3046-1	74 kW (99 HP)
Maximum torque	412(304)/1600 Nm(ft lb)/rpm
Emission class	EU Stage IIIA / U.S. EPA Tier 3

WEIGHT & DRIVING CHARACTERISTICS	
Operating weight	10 400 kg (22 930 lb)
Maximum weight	11 190 kg (24 670 lb)
Static linear load of front drum	30.9 kg/cm (173 lb/in)
Static linear load of rear drum	30.3 kg/cm (169.7 lb/in)
Max. transport speed	11 km/h (6.8 MPH)
Max. working speed	-
Climbing ability	30%
Turning radius inner (EDGE)	4650 mm (183.1 in)
Crab mode	160 mm (6.3 in)

STANDARD EQUIPMENT

- Open driver's platform with railing and protection against vandalism
- 2 amplitudes and 2 frequencies
- Hydrostatic drive front and rear drums
- Rotating and sliding operator's station
- Adjustable seat and steering column
- Pressurized sprinkling system
- Working lights front and rear
- Scrapers

OPTIONAL EQUIPMENT

- CE conformity kit
- ROPS cab ventilated heated
- ROPS protection frame on driver's platform
- Sun canopy for open platform version
- Air conditioning
- Radio
- Edge cutter
- IR Thermometer
- Additional working headlights