

ARX 90

ARTICULATED TANDEM ROLLER

EU Stage V / U.S. EPA Tier 4 Final



MEETING THE HIGHEST STANDARDS

The Ammann ARX 90 Tandem Roller provides features and benefits that ultimately lead to added value for owners of the heavy compactor. It also meets EU Stage V / U.S. EPA Tier 4 Final emissions standards. Compaction output is high and the system efficient. Each drum has an independent vibratory pump. The roller also features a heavy-duty, two-stage vibrator and easy adjustment of amplitude and frequency. The optional ACE^{force} system provides a host of benefits including measurement and documentation, evaluation of material stiffness, operator guidance and documentation.

PRODUCTIVITY

Multiple vibratory frequencies

Varied vibratory settings adjust compaction output for even more precise compaction control and higher quality

Advanced articulation joint

Permanent contact with the surface and a wide range of working widths maximises productivity

Machine customisation

Options make the machine a perfect match for diverse jobsites and varying customer needs

ERGONOMICS

Multi-functional display

The central display is located in front of the operator for optimal machine control and monitoring

Intelligent functions

Integrated advanced functions make machine more operator friendly, intuitive and safe

Operator station

An intuitively organized, fully adjustable operator station has all controls located within easy reach

SERVICEABILITY

Accessible engine compartment

Tool-free, wide-opening side doors on the engine compartment

Easy-to-reach maintenance points

All service points are conveniently located for easy access

Self-diagnostic system

The on-board, automated diagnostic system quickly identifies potential problems

APPLICATIONS

- Medium and large compaction sites
- Transport construction
- Municipal and town roads
- Motorways
- Airport runways
- Housing developments
- Industrial zones
- City centers

MAXIMUM RECOMMENDED COMPACTED LIFT THICKNESS AT OPTIMAL WORKING CONDITIONS

	Sand / Gravel	Mixed Soils	Silt	Clay	Stabilisation	Asphalt
ARX 90	0.4 m (16 in)	0.3 m (12 in)	-	-	0.2 m (8 in)	0.14 m (5.5 in)



ETOP
creat să reziste

Republica Moldova, MD-2023
mun. Chişinău, str. Uzinelor 90
+ /373/ 67 707 707
office@etop.md
www.etop.md

TECHNICAL SPECIFICATIONS
ARX 90 ARTICULATED TANDEM ROLLER
EU Stage V / U.S. EPA Tier 4 Final

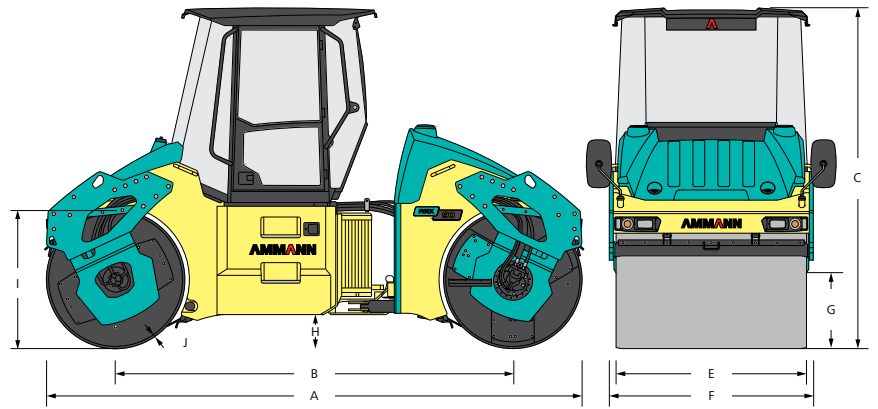

DIMENSIONS		
A	Machine length	4720 mm (185.8 in)
B	Wheelbase	3500 mm (137.8 in)
C	Machine height	3000 mm (118.2 in)
E	Drum width	1680 mm (66.1 in)
F	Machine width	1800 mm (70.9 in)
G	Side clearance	780 mm (30.7 in)
H	Ground clearance	300 mm (11.8 in)
I	Drum diameter	1220 mm (48.0 in)
J	Drum shell thickness	19 mm (0.7 in)

WEIGHT & OPERATING CHARACTERISTICS		
	ARX 90	ARX 90 HF
Operating weight	9720 kg (21 430 lb)	9720 kg (21 430 lb)
Operating weight max.	11 170 kg (24 630 lb)	11 170 kg (24 630 lb)
Stat. lin. load of front drum	28.5 kg/cm (159 lb/in)	28.5 kg/cm (159 lb/in)
Stat. lin. load of rear drum	29.4 kg/cm (159.6 lb/in)	29.4 kg/cm (154.6 lb/in)
Max. transport speed	10.5 km/h (6.5 MPH)	10.5 km/h (6.5 MPH)
Gradeability with / without vibr.	30 % / 25 %	30 % / 25 %
Turning radius inner (edge)	5470 mm (215.4 in)	5470 mm (215.4 in)
Drum offset	170 mm (6.7 in)	170 mm (6.7 in)

ENGINE	
Manufacturer	Deutz TCD3.6 L4
Power output ISO 14396	74.4 kW (100 HP)
Maximum torque	410/1600 Nm (ft lb)/rpm
Emmission class	EU Stage V / U.S. EPA Tier 4 Final
Exhaust gas after-treatment	EGR+DOC+DPF+SCR

COMPACTION FORCES		
	ARX 90	ARX 90 HF
Frequency I	38–42 Hz (2280–2520 VPM)	42–46 Hz (2520–2760 VPM)
Frequency II	45–54 Hz (2700–3240 VPM)	58–67 Hz (3480–4020 VPM)
Amplitude I	0.7 mm (0.028 in)	0.62 mm (0.024 in)
Amplitude II	0.34 mm (0.013 in)	0.23 mm (0.009 in)
Centrifugal force I	47–68kN (10 566–15 287 lbf)	56–70kN (12 590–15 737 lbf)
Centrifugal force II	69–84kN (15 511–18 884 lbf)	74–89kN (16 636–20 008 lbf)
Oscillation frequency	40 Hz (2400 VPM)	40 Hz (2400 VPM)
Oscillation amplitude	1.3 mm (0.051 in)	1.3 mm (0.051 in)
Oscillation force	77kN (17 310 lbf)	77kN (17 310 lbf)

MISCELLANEOUS	
Brakes operating	Hydrostatic
Brakes parking	Mechanical multiple-disc
Brakes emergency	Mechanical multiple-disc
Fuel tank capacity	220 l (58.1 gal)
Water tank capacity	840 l (222 gal)
Voltage	24 V

STANDARD EQUIPMENT

- CE conformity
- ROPS/FOPS Open platform with Plastic roof
- ATC - Ammann Traction Control
- Pressure water sprinkling with interval switch, 3 stage filtration and 2 pumps
- Lockable articulation joint with Oscillation and Offset (Crab mode)
- Foldable scrapers
- 2 amplitudes / Multiple frequencies
- Operator's station with one drive lever (RH)
- 170° Slideable, rotatable and horizontally adjustable driver's seat with armrests
- Multi-functional display for machine control and overview
- Adjustable Steering column
- Road lights (headlights, rearlights, turning signals, brake lights)
- Telematics Ready
- On-Board diagnostics
- Centralized draining points

OPTIONAL EQUIPMENT

- Cab with ROPS/FOPS
- Air condition
- Additional Lights 360° LED
- Warning beacon
- Double drum roller - Unsplitted drums with HF
- Double drum roller - Oscillating rear drum (unsplitted)
- Double drum roller - Front HF drum with Oscillating rear drum (unsplitted)
- Infrared thermometer
- Compaction Measuring System ACE^{force}
- Chip Spreader Ammann
- Edge cutter
- Rear view camera
- Telematics System ServiceLink (3 Years)
- GPS Q-Compaction
- Backup alarm
- Bio-degradable hydraulic oil
- Customer color
- Sun Films on glasses

ARX 90K

ARTICULATED TANDEM ROLLER

EU Stage IIIA / U.S. EPA Tier 3



ADDED VERSATILITY

The Ammann ARX 90K Combination Roller provides features and benefits that ultimately lead to added value for owners of this versatile compactor. Specifically, the roller provides the benefits of vibratory and pneumatic compactors in a single machine. The cab's design provides comfort that helps the operator stay focused and productive throughout the shift.

PRODUCTIVITY

Multiple vibratory frequencies

Varied vibratory settings adjust compaction output for even more precise compaction control and higher quality

Advanced articulation joint

Permanent contact with the surface and a wide range of working widths maximises productivity

Machine customisation

Options make the machine a perfect match for diverse jobsites and varying customer needs

ERGONOMICS

Multi-functional display

The central display is located in front of the operator for optimal machine control and monitoring

Intelligent functions

Integrated advanced functions make machine more operator friendly, intuitive and safe

Operator station

An intuitively organized, fully adjustable operator station has all controls located within easy reach

SERVICEABILITY

Accessible engine compartment

Tool-free, wide-opening side doors on the engine compartment

Easy-to-reach maintenance points

All service points are conveniently located for easy access

Self-diagnostic system

The on-board, automated diagnostic system quickly identifies potential problems

APPLICATIONS

- Medium and large compaction sites
- Transport construction
- Municipal and town roads
- Motorways
- Airport runways
- Housing developments
- Industrial zones
- City centers

MAXIMUM RECOMMENDED COMPACTED LIFT THICKNESS AT OPTIMAL WORKING CONDITIONS

	Sand / Gravel	Mixed Soils	Silt	Clay	Stabilisation	Asphalt
ARX 90K	0.3 m (12 in)	0.2 m (8 in)	-	-	0.15 m (6 in)	0.12 m (4.7 in)



ETOP
creat să reziste

Republica Moldova, MD-2023
mun. Chişinău, str. Uzinelor 90
+ /373/ 67 707 707
office@etop.md
www.etop.md

TECHNICAL SPECIFICATIONS
ARX 90K ARTICULATED TANDEM ROLLER
EU Stage IIIA / U.S. EPA Tier 3

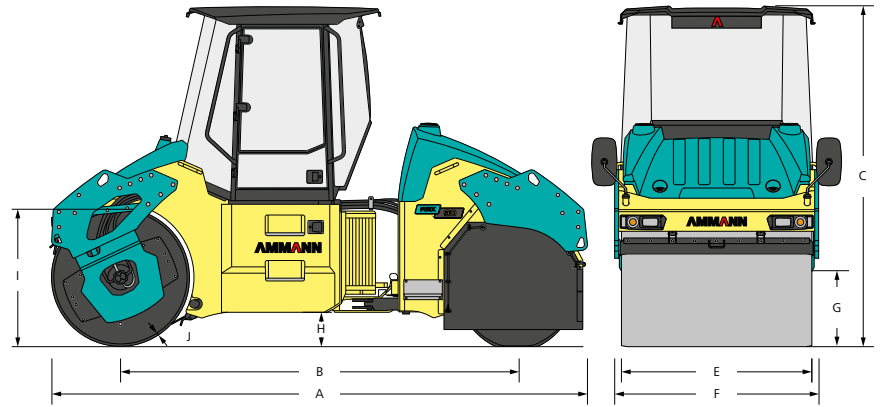

DIMENSIONS		
A	Machine length	4720 mm (185.8 in)
B	Wheelbase	3500 mm (137.8 in)
C	Machine height	3000 mm (118.2 in)
E	Drum width	1680 mm (66.1 in)
F	Machine width	1800 mm (70.9 in)
G	Side clearance	780 mm (30.7 in)
H	Ground clearance	300 mm (11.8 in)
I	Drum diameter	1220 mm (48.0 in)
J	Drum shell thickness	19 mm (0.7 in)

WEIGHT & OPERATING CHARACTERISTICS	
Operating weight	9320 kg (20 550 lb)
Operating weight max.	10 760 kg (23 720 lb)
Stat. lin. load of front drum	28.4 kg/cm (159 lb/in)
Max. transport speed	10.5 km/h (6.5 MPH)
Gradeability with / without vibr.	30% / 25%
Turning radius inner (edge)	5470 mm (215.4 in)
Drum offset	170 mm (6.7 in)

ENGINE	
Manufacturer	Deutz TCD3.6 L4
Power output ISO 14396	74.4 kW (100 HP)
Maximum torque	410/1600 Nm (ft lb)/rpm
Emmission class	EU Stage IIIA / U.S. EPA Tier 3
Exhaust gas after-treatment	EGR

COMPACTION FORCES	
Frequency I	38–42 Hz (2280–2520 VPM)
Frequency II	45–54 Hz (2700–3240 VPM)
Amplitude I	0.7 mm (0.028 in)
Amplitude II	0.34 mm (0.013 in)
Centrifugal force I	47–68kN (10 566–15 287 lbf)
Centrifugal force II	69–84kN (15 511–18 884 lbf)

MISCELLANEOUS	
Brakes operating	Hydrostatic
Brakes parking	Mechanical multiple-disc
Brakes emergency	Mechanical multiple-disc
Fuel tank capacity	220 l (58.1 gal)
Water tank capacity	840 l (222 gal)
Anti-adhesive tank	28 l (7.4 gal)
Tire size	11,00x20"16PR
Voltage	24 V

STANDARD EQUIPMENT

- CE conformity
- ROPS/FOPS Open platform with Plastic roof
- Pressure water sprinkling with interval switch, 3 stage filtration and 2 pumps
- Combi-version: One non-split drum / 4 tyres in rear
- Combi-version: Front and rear drive and front vibration
- Combi-version: Incl. Emulsion-spraying and Thermal aprons
- Lockable articulation joint with Oscillation and Offset (Crab mode)
- Foldable scrapers
- 2 amplitudes / Multiple frequencies
- Operator's station with one drive lever (RH)
- 170° Slideable, rotatable and horizontally adjustable driver's seat with armrests
- Multi-functional display for machine control and overview
- Adjustable Steering column
- Road lights (headlights, rearlights, turning signals, brake lights)
- Telematics Ready
- On-Board diagnostics
- Centralized draining points

OPTIONAL EQUIPMENT

- Cab with ROPS/FOPS
- Air condition
- Additional Lights 360° LED
- Warning beacon
- Combi roller - Unsplitted drum with HF
- Infrared thermometer
- Compaction Measuring System ACE^{force}
- Chip Spreader Ammann
- Edge cutter
- Rear view camera
- Telematics System ServiceLink (3 Years)
- GPS Q-Compaction
- Backup alarm
- Bio-degradable hydraulic oil
- Customer color
- Sun Films on glasses

ARX 90C

ARTICULATED TANDEM ROLLER

EU Stage V / U.S. EPA Tier 4f



MEETING THE HIGHEST STANDARDS

The Ammann ARX 90C Combination Roller provides the benefits of vibratory and pneumatic compactors in a single machine while meeting EU Stage V / U.S. EPA Tier 4f emissions standards. The optional ACE^{force} system provides a host of benefits including measurement and documentation, evaluation of material stiffness, operator guidance and documentation.

PRODUCTIVITY

Multiple vibratory frequencies

Varied vibratory settings adjust compaction output for even more precise compaction control and higher quality

Advanced articulation joint

Permanent contact with the surface and a wide range of working widths maximises productivity

Machine customisation

Options make the machine a perfect match for diverse jobsites and varying customer needs

ERGONOMICS

Multi-functional display

The central display is located in front of the operator for optimal machine control and monitoring

Intelligent functions

Integrated advanced functions make machine more operator friendly, intuitive and safe

Operator station

An intuitively organized, fully adjustable operator station has all controls located within easy reach

SERVICEABILITY

Accessible engine compartment

Tool-free, wide-opening side doors on the engine compartment

Easy-to-reach maintenance points

All service points are conveniently located for easy access

Self-diagnostic system

The on-board, automated diagnostic system quickly identifies potential problems

APPLICATIONS

- Medium and large compaction sites
- Transport construction
- Municipal and town roads
- Motorways
- Airport runways
- Housing developments
- Industrial zones
- City centers

MAXIMUM RECOMMENDED COMPACTED LIFT THICKNESS AT OPTIMAL WORKING CONDITIONS

	Sand / Gravel	Mixed Soils	Silt	Clay	Stabilisation	Asphalt
ARX 90C	0.3 m (12 in)	0.2 m (8 in)	-	-	0.15 m (6 in)	0.12 m (4.7 in)



ETOP
creat să reziste

Republica Moldova, MD-2023
mun. Chişinău, str. Uzinelor 90
+ /373/ 67 707 707
office@etop.md
www.etop.md

TECHNICAL SPECIFICATIONS
ARX 90C ARTICULATED TANDEM ROLLER
EU Stage V / U.S. EPA Tier 4f

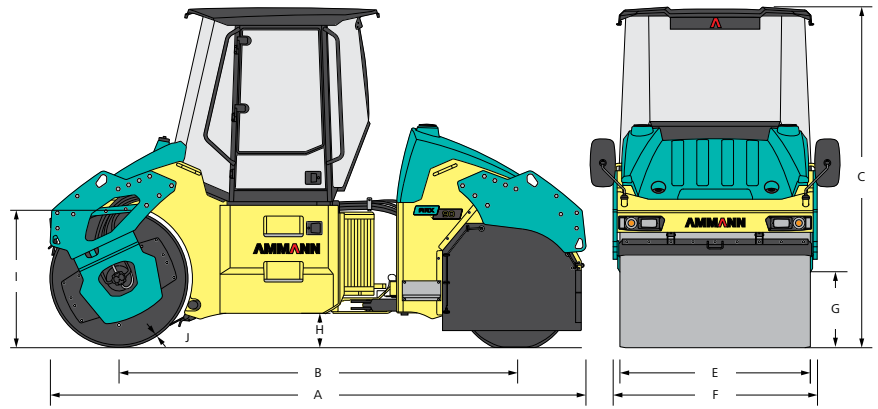

DIMENSIONS		
A	Machine length	4720 mm (185.8 in)
B	Wheelbase	3500 mm (137.8 in)
C	Machine height	3000 mm (118.2 in)
E	Drum width	1680 mm (66.1 in)
F	Machine width	1800 mm (70.9 in)
G	Side clearance	780 mm (30.7 in)
H	Ground clearance	300 mm (11.8 in)
I	Drum diameter	1220 mm (48.0 in)
J	Drum shell thickness	19 mm (0.7 in)

WEIGHT & OPERATING CHARACTERISTICS	
Operating weight	9570 kg (21 100 lb)
Operating weight max.	11 040 kg (24 340 lb)
Stat. lin. load of front drum	28.5 kg/cm (159 lb/in)
Max. transport speed	10.5 km/h (6.5 MPH)
Gradeability with / without vibr.	25% / 30%
Turning radius inner (edge)	5470 mm (215.4 in)
Drum offset	170 mm (6.7 in)

ENGINE	
Manufacturer	Deutz TCD3.6 L4
Power output ISO 14396	74.4 kW (100 HP)
Maximum torque	410/1600 Nm (ft lb)/rpm
Emmission class	EU Stage V / U.S. EPA Tier 4f
Exhaust gas after-treatment	EGR+DOC+DPF+SCR

COMPACTION FORCES	
Frequency I	38–42 Hz (2280–2520 VPM)
Frequency II	45–54 Hz (2700–3240 VPM)
Amplitude I	0.7 mm (0.028 in)
Amplitude II	0.34 mm (0.013 in)
Centrifugal force I	47–68kN (10 566–15 287 lbf)
Centrifugal force II	69–84kN (15 511–18 884 lbf)

MISCELLANEOUS	
Brakes operating	Hydrostatic
Brakes parking	Mechanical multiple-disc
Brakes emergency	Mechanical multiple-disc
Fuel tank capacity	220 l (58.1 gal)
Water tank capacity	840 l (222 gal)
Anti-adhesive tank	28 l (7.4 gal)
Tire size	11,00x20"16PR
Voltage	24 V

STANDARD EQUIPMENT

- CE conformity
- ROPS/FOPS Open platform with Plastic roof
- Pressure water sprinkling with interval switch, 3 stage filtration and 2 pumps
- Combi-version: One non-split drum / 4 tyres in rear
- Combi-version: Front and rear drive and front vibration
- Combi-version: Incl. Emulsion-spraying and Thermal aprrons
- Lockable articulation joint with Oscillation and Offset (Crab mode)
- Foldable scrapers
- 2 amplitudes / Multiple frequencies
- Operator's station with one drive lever (RH)
- 170° Slideable, rotatable and horizontally adjustable driver's seat with armrests
- Multi-functional display for machine control and overview
- Adjustable Steering column
- Road lights (headlights, rearlights, turning signals, brake lights)
- Telematics Ready
- On-Board diagnostics
- Centralized draining points

OPTIONAL EQUIPMENT

- Cab with ROPS/FOPS
- Air condition
- Additional Lights 360° LED
- Warning beacon
- Combi roller - Unsplitted drum with HF
- Infrared thermometer
- Compaction Measuring System ACE^{force}
- Chip Spreader Ammann
- Edge cutter
- Rear view camera
- Telematics System ServiceLink (3 Years)
- GPS Q-Compaction
- Backup alarm
- Bio-degradable hydraulic oil
- Customer color
- Sun Films on glasses