

CARMIX 5.5XL

CARMIX
4x4 mixers & dumpers

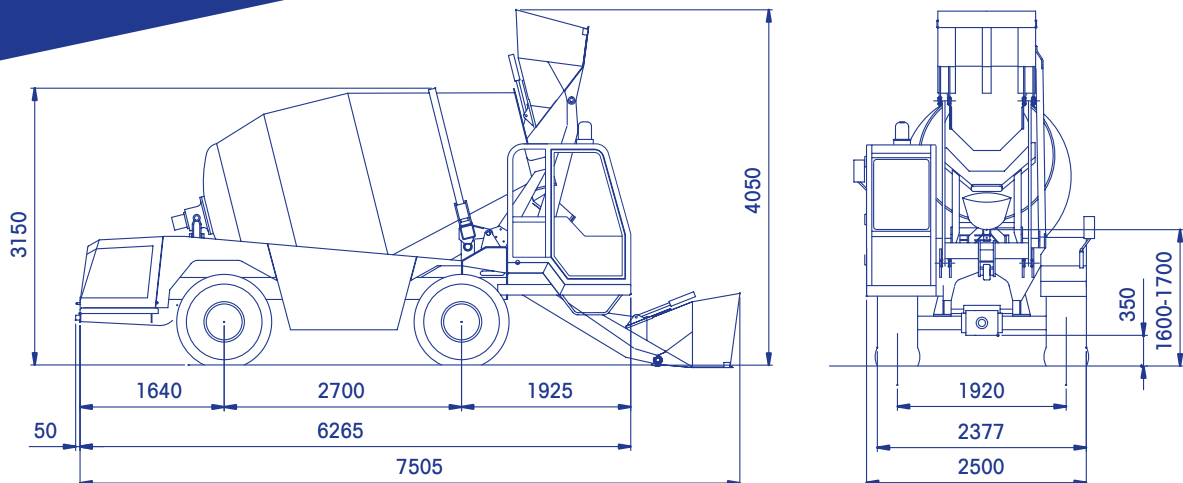

ACCESSORIES ON DEMAND

Electronic weighing system "LOAD CELLS" with printer

High-pressure washing pump (90 BAR) with gun

Clima (air conditioning plus heater)

Spare wheel

Additional discharging chute (cm 100)

Additive Plant

CARMIX 5.5XL



MIXING UNIT

Drum capacity 7.600 liters. Concrete drum output: 5,5 m³. EN 206-1 in slump S1 Class, yield not vibrate. Double mixing screws, cover for emergency unloading. Drum rotation by hydraulic motor and planetary reducers. Mixing and discharging speed independent from r.p.m. of diesel engine. Discharging by reversing drum.



ENGINE

Cummins turbo-diesel QBS 4.5 stage 3A tier III, 4 cylinders 119 KW (161 hp). Engine mounted transversal on the rear.



TRANSMISSION

Hydrostatic Bosch Rexroth. Pump and motor are connected to the differentials through a 2 speed reducer (working and transfer). 4 wheel drive and steering.



AXLES

Dana Spicer with oil bath disc brakes and planetary reducers..



SPEED

Working speed from 0 to 10 km/h, road transfer from 0 to 30 km/h.



CABIN

Front cab on side of loading shovel. ROPS-FOPS type (UNI U50.01.478.0) complete with double closing door and rear view camera. Klima, air conditioning heater available upon request.



HYDRAULIC SYSTEM

Three circuits. 2 variable outlet pumps for hydrostatic transmission and drum rotation. 2 gear pumps for services. Inlet and outlet filter. Heat exchanger water/oil-air type.



JOYMIX

All hydraulic functions of shovel controlled by a single - fully servo controlled Joystick.



WEIGHING

Electronic system. "Load cells" acting on the drum, display and printer in the cab. (on request).



LOADING SHOVEL SELF ARTICULATED

Effective capacity per load 600 liters, complete with hydraulic opening gate.



CHUTE

Hydraulic slewing and hydraulic tilting controlled from the cab. 2 extra chutes included.



WATER SYSTEM

Self-contained. Hydraulic driven water pump 400 lt/min, water meter, washing outlet. High pressure water pump (on request).



GRADIENT

Fully loaded 30%.



BRAKES

Oil bath disc brakes inside differential axles. Twin independent circuits. Negative hydraulic parking brake.



TYRES

Off road industrial type 18-19,5 PR 16.



STEERING

Hydrostatic. 3 way steering. Radius: internal mm. 1800 - external mm. 4000



ELECTRIC SYSTEM

12 Volt. 155 Ah battery for electric starter and road lighting. Safety battery cut-off.



TANKS

Water: 2x600 liters. Diesel: 150 liters. Hydraulic oil: 120 liters.



CHASSIS

Steel profile specially engineered for off-road operations.



WEIGHT

About Kg. 8.700, equally distributed on both axles.



SAFETY

Machine equipped with checking and block valves for maximum safety of the operator.



CATALOGUE

The machine is equipped with Use and Maintenance and Spare Parts manuals according to CE regulations.



ETOP
creat să reziste

Republica Moldova, MD-2023
mun. Chişinău, str. Uzinelor 90
+ /373/ 67 707 707
office@etop.md
www.etop.md