

CARMIX 2.5TT

CARMIX
4x4 mixers & dumpers

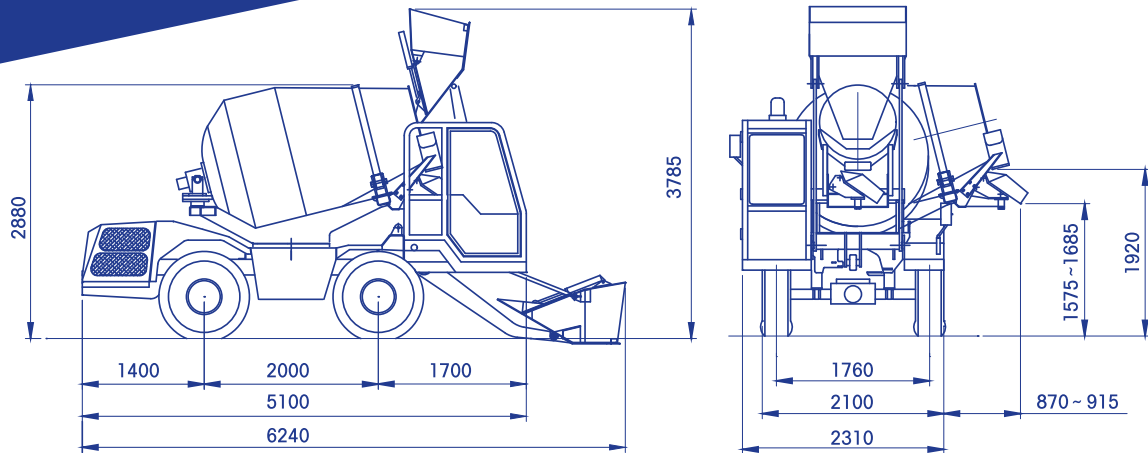

ACCESSORIES ON DEMAND

.....
Electronic weighing system "LOAD CELLS" with printer
.....

.....
High-pressure washing pump (90 BAR) with gun
.....

.....
Clima (air conditioning plus heater)
.....

.....
Spare wheel
.....

.....
Additional discharging chute (100 cm)
.....

CARMIX 2.5TT



MIXING UNIT

Drum capacity 3.450 liters. Concrete drum output: 2,5 m³. EN 206-1 IN SLUMP S1 Class, yield not vibrated. Double mixing screws, cover for emergency unloading. Drum rotation by hydraulic motor and planetary reducers. Mixing and discharging speed independent from r.p.m. of diesel engine. Discharging by reversing drum. The mixing unit is slewing hydraulically through 270° for high discharge at 1,9 m on the four sides of the vehicle.



ENGINE

Perkins Stage III - Tier 3A 1104D-44T Turbo-diesel, watercooled, 4 cylinders. Rated power KW 62,5 (84 HP) set at 2.200 rpm. Engine mounted transversal on the rear.
Perkins Stage V - Tier 4F 904J-E36TA Turbo-diesel, 55,4 Kw (74 Hp).



TRANSMISSION

Hydrostatic Bosch Rexroth. Pump and motor are connected to the differentials through a 2 speed reducer (working and transfer). 4 wheel drive and steering.



AXLES

Dana Spicer with oil bath disc brakes and planetary reducers.



SPEED

Working speed from 0 to 9 km/h, road transfer from 0 to 25 km/h. Electric servo control.



CABIN

Front cab on side of loading shovel. ROPS-FOPS (UNI 11023) type complete with double closing door and rear view camera. Clima, air conditioning heater available upon request.



HYDRAULIC SYSTEM

Three circuits. 2 variable outlet pumps for hydrostatic transmission and drum rotation. 2 gear pumps for services. Inlet and outlet filter. Heat exchanger water/oil-air type.



JOYMIX

All hydraulic functions of shovel controlled by a single - fully servo controlled Joystick.



WEIGHING

Electronic system. "Load cells" acting on the drum, display and printer in the cab. (on request)



LOADING SHOVEL SELF ARTICULATED

Effective capacity per load 400 liters, complete with hydraulic opening gate.



CHUTE

Slewing and hydraulically tilting. Fitted with two pins easily detachable to increase the discharge height. 2 extra chutes included.



WATER SYSTEM

Self-contained. Hydraulic driven water pump 400 lt/min, water meter, washing outlet. High pressure water pump (on request).



GRADIENT

Fully loaded 30%.



BRAKES

Oil bath disc brakes inside differential axles. Twin independent circuits. Negative hydraulic parking brake.



TYRES

Off road industrial type 12.5-20 PR 12.



STEERING

Hydrostatic. 3 ways steering. Radius: mm. 1500, external mm 3500.



ELECTRIC SYSTEM

12 Volt. 120 Ah battery for electric starter and road lighting. Safety battery cut-off.



TANKS

Water: 2x270 liters. Diesel: 105 liters. Hydraulic oil: 80 liters.



CHASSIS

Steel profile specially engineered for off-road operations.



WEIGHT

About Kg. 6.000. Equally distributed on both axles.



SAFETY

Machine equipped with checking and block valves for maximum safety of the operator. Self control avoids drum to slew if shovel's arm is lifted.



CATALOGUE

The machine is equipped with Use and Maintenance and Spare Parts Manuals according to CE regulations.



ETOP
creat să reziste

Republica Moldova, MD-2023
mun. Chişinău, str. Uzinelor 90
+ /373/ 67 707 707
office@etop.md
www.etop.md