

CARMIX 45FX

CARMIX
4x4 mixers & dumpers

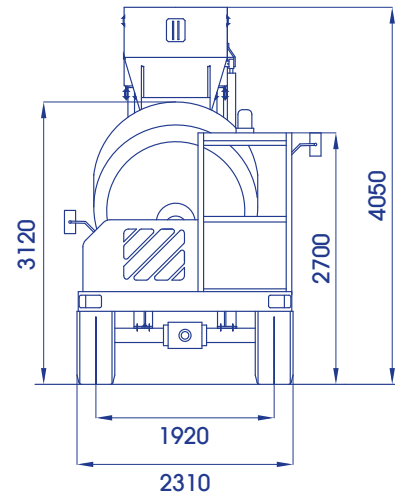
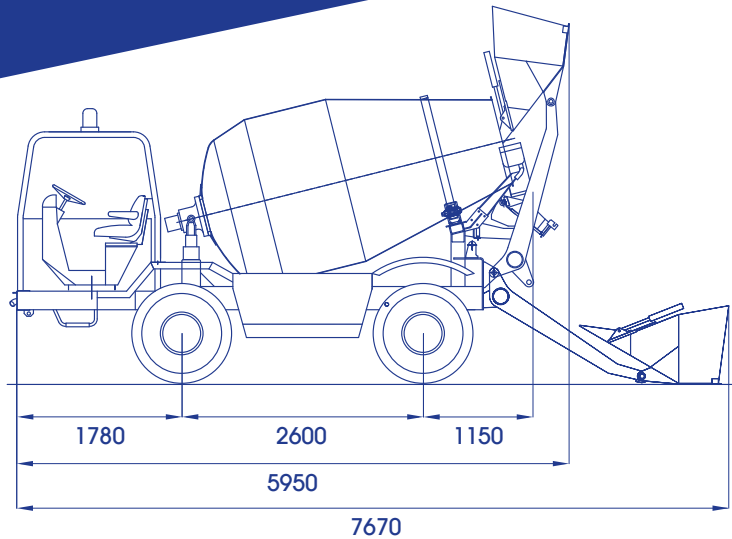

ACCESSORIES ON DEMAND

Electronic weighing system "LOAD CELLS" with printer

High-pressure washing pump

Rear camera (front camera standard)

Spare wheel

CARMIX 45FX



MIXING UNIT

Drum capacity 6050 liters. Concrete drum output: 4,5 m³. Double mixing screws, cover for emergency unloading. Drum rotation by hydraulic motor and planetary reducers. Mixing and discharging speed independent from r.p.m. of diesel engine. Discharging by reversing drum.



ENGINE

Perkins 1104D - 44TA Turbo-Diesel Tier 3, water-cooled, 4 cylinders Tier 3. Power 83 kW (111 HP) set at 2200 rpm.



TRANSMISSION

Hydrostatic Bosch-Rexroth. Heavy duty differential axles with planetary reducers. Front axle swinging and steering. Rear axle fixed.



AXLES

Come with oil bath disc brakes and planetary reducers.



SPEED

Working speed from 0 to 10 km/h, road transfer from 0 to 25 km/h. Electric servo control.



DRIVING SEAT

ROPS-FOPS canopy. Reversible seat with automatic inversion of hydraulic steering circuit. Closed cabin on request. Air conditioning on request.



HYDRAULIC SYSTEM

3 independent circuits. 2 variable outlet pumps for hydrostatic transmission and drum rotation. 1 pump for services. Inlet and outlet filter. Heat exchanger water/oil-air type.



WEIGHING

Electronic system. "Load cells" acting on the drum, display and printer in the cab. (on request)



LOADING SHOVEL SELF ARTICULATED

Effective capacity per load 600 liters, complete with hydraulic opening gate.



CHUTE

Slewing and hydraulically tilting 2 extra chutes included.



WATER SYSTEM

Self-contained. Hydraulic driven water pump, water meter, washing outlet.



GRADIENT

A pieno carico 30%.



BRAKES

Oil bath disc brakes inside differential axles. Twin independent circuits. Negative hydraulic parking brake.



TYRES

Off road industrial type 16/70-20 PR14.



STEERING

Hydrostatic. 3 wayS steering. Radius: internal mm. 1800 - external mm. 3800.



ELECTRIC SYSTEM

12 Volt. 120 Ah battery for electric starter and road lighting. Safety battery cut-off.



TANKS

Water: 2x590 liters. Diesel: 130 liters. Hydraulic oil: 80 liters.



CHASSIS

Steel profile specially engineered for off-road operations.



WEIGHT

In running order Kg. 7000 equally distributed on both axles.



SAFETY

Machine equipped with checking and block valves for maximum safety of the operator.



CATALOGUE

The machine is equipped with Use and Maintenance and Spare Parts manuals according to CE regulations



ETOP
creat să reziste

Republica Moldova, MD-2023
mun. Chişinău, str. Uzinelor 90
+ /373/ 67 707 707
office@etop.md
www.etop.md