

TANA



TANA H SERIES

LANDFILL COMPACTOR

***ECO* H260 H260**

TANA FROM WASTE TO VALUE®

H260eco / H260

TANA Landfill Compactor

GENERAL INFORMATION

Weight	29,000 - 30,500 kg / 28,700 - 30,200 kg
Total length	8 260 mm
Total width	3 650 mm
Total height	4 410 mm
Wheel base	4 050 mm
Ground clearance	840 mm
Length without dozer blade	6 730 mm
Width without dozer blade	3 250 mm
Inside turning radius	3 880 mm
Driving speed ranges	0-4 km/h 0-10 km/h
Maximum crushing force	150 kN

COMPACTION DRUMS

Uniform full-width drums with forged crushing teeth made of wear resistant steel. Adjustable, forged wear-resistant steel scraper bars on both sides of the drums. Adjustable, wear resistant steel wire cutters in the ends of drums.

Crushing/compaction width, front drum	2660 mm
Crushing/compaction width, rear drum	2660 mm
Diameter including crushing teeth	1620 mm
Height of crushing teeth	200 mm
Number of crushing teeth, pcs (front+rear)	80+80 pcs
Number of scraper bars	14 + 14 pcs
Number of wire cutters	4 + 4 pcs

DOZER BLADE

The dozer blade is operated with two hydraulic cylinders and equipped with two arms. Arm joints are with hardened pins and spherical bearings.

Width	3650 mm
Height	1740 mm
Movement above ground level	1270 mm
Movement below ground level	150 mm

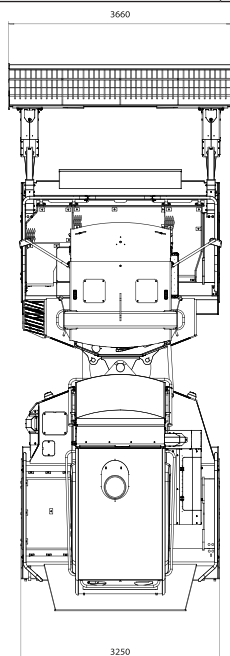

ENGINE

Cummins L9-C365

- Turbo charged, 6 cylinders in line, water-cooled, after-cooled, four-stroke diesel engine
- Fulfills Tier 4 Final, EU Stage V non-road emission certificates

Maximum power	365 BHP(272kW)@2100 RPM
Maximum torque	1561 Nm(1151lb-ft) @1400 RPM
Power rating	365 BHP(272kW)@2100 RPM

Cummins QSL9-C250

- Turbo charged, 6 cylinders in line, water-cooled, after-cooled, four-stroke diesel engine
- Fulfills Tier 3, EU Stage IIIA non-road emission certificates

Maximum power	340 BHP(253kW)@1900 RPM
Maximum torque	1085 Nm(800lb-ft) @1400 RPM
Power rating	250 BHP(186kW)@2000 RPM

Engine equipment

- Dry type air cleaner with replaceable primary and safety element
- Service indicator
- Fuel filter and water separator 1 pc
- Oil filter 1 pc
- Radiator + separate charge air cooler
- Starter motor 24V
- Alternator 24V, 110A

FRAME

The frame is constructed of two modular drum frames connected together with a longitudinal upper frame. The drum frame acts as a shell around the drum, which helps to prevent waste raising to the upper parts of the machine from below.

The upper frame is equipped with center point articulated steering operated with two hydraulic cylinders.

- Articulation links are equipped with hardened pins and spherical steel bearings
- The angle of articulation to the left or right is 40 degrees

SERVICE PLATFORMS AND PROTECTION

Service platforms and steps are equipped with banisters and anti-slide surface. Engine and powerpack are protected with lockable hood (bonnet). Opening of hood is made easier by using wind hooks.

VANDALISM PROTECTION

- Lockable cabin, engine compartment and fuel tank filling cap
- Electronic key for ignition

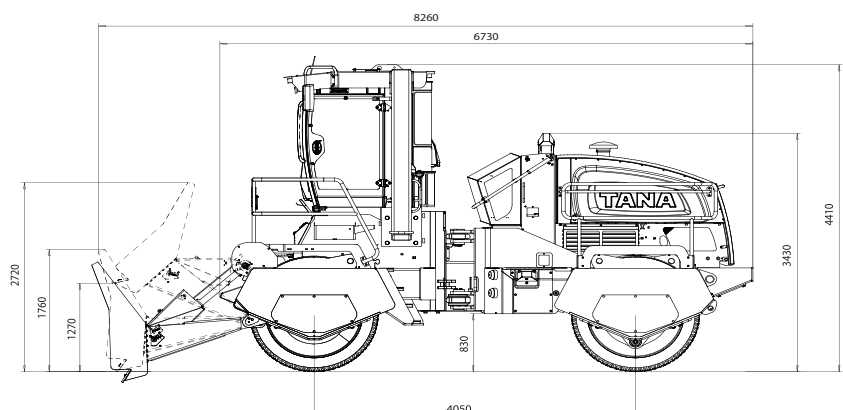

CABIN AND CONTROLS

Equipment

- Pressurized, heat and sound insulated cabin with cabin lights
- Insulation materials in accordance with ISO 3795
- Laminated safety glass windows
- Socket for mobile phone charger, radio with CD/MP3 player
- Front and rear windshield intermittent wipers and washers, sun cover in front
- Heater and A/C unit
- Emergency exit, lockable door, shelf and lockers, external rear view mirrors, inside mirror
- Replaceable cabin air filters in accordance with EUROVENT

Gauges included in TANA Control System (TCS)

- Engine oil pressure, engine intake air temperature, engine oil and hydraulic oil temperatures, engine coolant temperature
- Final drive gearbox temperatures
- Fuel levels, total fuel consumption
- Voltage, tachometer, boost pressure, engine working hours
- Engine load rate



Spacious cabin with excellent visibility for operational safety & efficiency.



High resolution color touch screen for easy operation.

Controls

- Transmission and parking brake on/off
- Traction control
- Emergency stop
- Start/Stop switch: power on/off, start/stop
- Heater and air conditioning, cabin temperature control
- Windshield wipers and washers
- Headlights
- Additional lights
- Windshield wipers and washers

Joystick controls integrated in arm-rests

- Return to neutral position automatically when released and all related movements will stop
- Left hand joystick for control of driving speed and direction as well as control of optional bucket/accessory control, speed range selection by pressing a button, horn
- Right hand joystick for control of steering and dozer blade

System warnings in TCS

(indicator light, acoustic warning and alarm log)

- Engine over speed
- Hydraulic oil temperature (both high and low)
- Low hydraulic oil level
- High hydraulic oil contamination
- Fuel level
- Gear box temperature (both high and low)
- Hydraulic oil return line filter clogging
- Charge pressure filter contamination
- Low charge pressure
- Voltage (both high and low)
- In addition to above all the alarms from the diesel engine control module (including low engine oil pressure, high coolant temperature, etc).

ROPS / FOPS

Integrated in cabin structure

- ROPS in accordance with ISO 3471:2008
- FOPS in accordance with ISO 3449:2005

Weights and measurements are given within normal tolerances. Manufacturer reserves the right to alter the above as necessary. Some features shown may be optional and not standard.



H260eco / H260

TANA Landfill Compactor

POWER TRANSMISSION

- Closed circuit, hydrostatic transmission
- Separate systems for both drums
- Two driving speed ranges
- Control of driving speed and direction with one lever
- Stepless speed control

Pumps

- One tandem pump arrangement
- Variable displacement axial piston pumps with electrical proportional control

Motors

- Two variable displacement plug-in motors

Cooling of hydraulic system

- Air-operated oil cooler
- Openable air filtration screen

Hydraulic oil filtration

- Return line filter and two charge pressure filters
- Hydraulic oil filling filter

Final drive gearboxes

- Transmits hydraulic output to the drums
- Three-stage planetary gearboxes (2 pcs)
- Integrated hydraulic oil pressure released multiplate parking brake
- Splash lubrication system

BRAKES

- Service brakes: hydrostatic transmission acts as service brakes, separate circuits for both drums
- Parking/emergency brakes: hydraulic oil-released, spring-actuated multi-plate parking brake integrated in planetary gearboxes

AUXILIARY HYDRAULICS

Open circuit system with electro-hydraulic load sensing (LS) control

Pump

- Variable displacement axial piston pump

Directional control valve

- Electro-hydraulic proportional control

HYDRAULIC OIL TANK

The hydraulic oil tank is located inside the engine hood

- Electrical filling pump with automatic stop function, separate filter in oil filling connection
- Oil level sensor with alarm
- Breather filter

FUEL TANK

Tank (capacity 655 l) is located inside the upper frame under the operator cabin

- Lockable filling cap
- Service hatch
- Suction strainer
- Drain valve
- Level sensor with alarm

ELECTRICAL EQUIPMENT

- 24 VDC system
- Batteries 12 V 170 Ah, 2 pcs
- LED lights: front and rear light bars on the cabin roof, in addition at rear separate lights (2 pcs)
- Horn
- Socket for hand light in engine compartment
- Back-up alarm, main circuit breaker, voltage reducer for radio

TANA ProTrack®

State of the art information management system

Maximum uptime

- Remote access for quicker and more accurate trouble shooting by the distributor and TANA technical support
- Critical alarm notifications to several receivers by e-mail
- Reminders for scheduled maintenance to several receivers by e-mail

Accuracy to cost follow-up through

- TANA ProTrack® reports (additional option)
- Monthly operational reports to given e-mails on e.g. working hours, fuel consumption, work load...



For more information, contact your local Tana distributor



ETOP
creat să reziste

Republica Moldova, MD-2023
mun. Chișinău, str. Uzinelor 90
+ /373/ 67 707 707
office@etop.md
www.etop.md