

DRIVE BELTS	AUTOMATION GRADE	BOX FORMAT	FORMAT SETTING	SEALING TECHNOLOGY
SIDE	SEMI-AUTOMATIC	UNIFORM	MANUAL	PSA TAPES

NASTRO-SB L

SEMI-AUTO UNIFORM SIZE

CASE SEALER

Nastro-SB L is a semi-automatic case sealing machine with double side drive belts, designed and engineered by SIAT to seal with adhesive tapes both upper and lower sides of uniform size boxes with manual adjustment, from small to very big dimensions. This model incorporates an advanced Logic, providing full diagnostics, production control and machine parameters through a dedicated Control Panel



KEY BENEFITS

PRODUCTION GUARANTEED

Easy and fast manual box adjustment with simultaneous upper & lower flaps sealing to overcome manual operations, reaching up to 30 box per minute

THE POWER OF FLEXIBILITY

Available in different set up and configurations to be able to perfectly process a huge variety of box dimension, covering the market needs.

PERFECT BOX SEALING

Dual 75mm side drive belts with the full series of SIAT K taping units available to be installed, from 25 to 75mm width

SMART & EFFECTIVE

Production data collection, alarm diagnostics and consumables management to upgrade the control of the end-of-line processes, even from remote

SAFETY FIRST

Pinch points eliminated, central or lateral double emergency buttons, lockable electrical switch and CE compliancy to guarantee ergonomic and safe operations

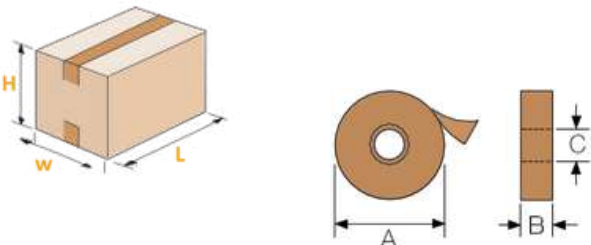

L5 - Machine Weight (kg)	250
L6 - Machine Weight (kg)	260
L8 - Machine Weight (kg)	280

SPECIFICATIONS

Boxes

Nastro-SB L5	Standard Box Version	Low Box Version
Box Min (mm) LxWxH	120 x 150 x 90*	120 x 80 **x 60**
Box Max (mm) LxWxH	∞ x 500 x 500	∞ x 500 x 500
Nastro-SB L6	Standard Box Version	Low Box Version
Box Min (mm) LxWxH	120 x 150 x 90*	120 x 80 **x 60**
Box Max (mm) LxWxH	∞ x 650 x 650	∞ x 650 x 650
Nastro-SB L8	Standard Box Version	Low Box Version
Box Min (mm) LxWxH	120 x 150 x 90*	120 x 80 **x 60**
Box Max (mm) LxWxH	∞ x 800 x 800	∞ x 800 x 800
Box Type	RSC, HSC, FEFCO 0200/0201	
Flute Type	B-C-E	
Min-Max Box Weight (kg)	0,5-32	
* 90 with 30mm leg, 100 with 50mm leg, 120 with 70mm leg		
** Considering the smallest unit in displacement configuration		

Machine

Productivity up to (bpm)	30
Based on the shortest processible box length, operator speed, box and tape quality	
Belt Speed (m/min)	26 - 35 (variable)
Operator side	Left - Right
(B) Taping Units	K25 (1"/25mm) - K38 (1,5"/38MM) - K11 (2"/50mm) - K12 (3"/75mm)
Tape Legs (mm)	30 - 50 - 70
Processable Tapes	PVC / OPP / PET / Paper
(A) Tape Reel Max DIA (mm)	410
(C) Inner Tape Core (mm)	76
Workbench height (mm)	540-800
Air Consumption (NI/Cycle)	-
Power Supply	400V 50/60Hz 3PH+N+PE 220/240V 50/60Hz 1PH+N+PE
Pneumatic Supply (bar)	-
Installed Power (kW)	0,51
Power Absorption (Amps)	3,4
L5 - Machine Dimensions LxWxH (mm)	1.100 x 1.085 x 1.315-1.575
L6 - Machine Dimensions LxWxH (mm)	1.100 x 1.240 x 1.460-1.720
L8 - Machine Dimensions LxWxH (mm)	1.100 x 1.390 x 1.575-1.835

KEY FEATURES

Perfect Box Traction

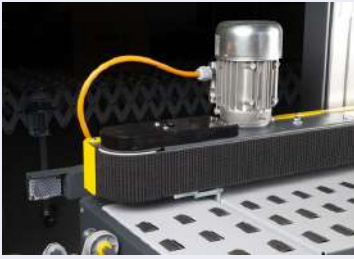

Double screw manually adjustable columns and double screw 75mm side drive belts to guarantee centered and stable box sealing

Best-in-class Taping Unit



Equipped with SIAT K Taping Units, a market benchmark which offers:

- Smooth and consistent tape application
- Fast reel change and threading with plug&play system

Scale Up for Big Boxes

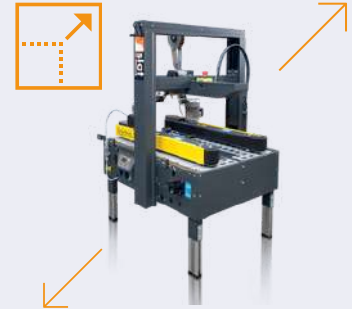

Different set up are available to cover major market needs in terms of box dimension, from 500 up to 800mm.

Logic On Board



Dedicated Logic to bring box sealing to a next level: parameters setting, box counting, tape consumption, alarms, process failures, cycle detection are only some of the available features.

Down to Small Boxes



Low Boxes Version with displaceable Integrated taping units can enhance the limits allowing to process very small and very narrow boxes

Remote Monitoring System



Selecting one of the SIAT Remote Service Packages, it is possible to have real-time monitoring of the information embedded in the Logic from multiple devices

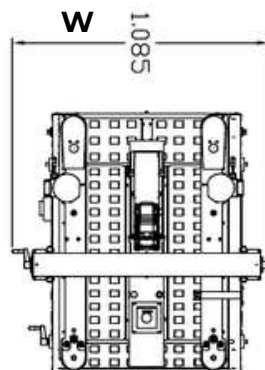
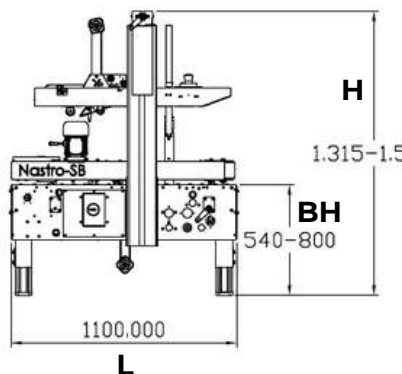

OPTIONALS

Safety Fences
Prolonged Motorization
Wheels ¹
Higher Legs ²
Lower Legs ³
Passive 3-flap folder
Conveyors: <u>GTL- GTR</u> (extendable conveyors), <u>RG</u> (roller conveyor)
¹ Workbench height becoming 650 - 910
² Workbench height becoming 760 - 1020
³ Workbench height becoming 440 - 700

IoT Optirun System
End/Brake Tape Device
Pneumatic Taping Unit VENTO 50-75