

DRIVE BELTS	AUTOMATION GRADE	BOX FORMAT	FORMAT SETTING	SEALING TECHNOLOGY
DUAL TOP & BOTTOM	SEMI-AUTOMATIC	UNIFORM	MANUAL	PSA TAPES

SK20-SK27

SEMI-AUTO UNIFORM SIZE CASE SEALER



SK20 is a semi-automatic case sealing machine with double top&bottom drive belts, designed and engineered by SIAT to seal with adhesive tapes both upper and lower sides of uniform size boxes with manual adjustment, from small to medium dimensions. It is also available in a bigger version, SK27, able to process larger size boxes.



KEY BENEFITS

PRODUCTION GUARANTEED

Easy and fast manual box adjustment with simultaneous upper & lower flaps sealing to overcome manual operations, reaching up to 20 box per minute

LIFETIME QUALITY

Robust Italian design with best-in-class components to guarantee long-lasting heavy duty operations

PERFECT BOX SEALING

Dual Top&Bottom drive belts with SIAT K taping units available for 50 mm (2") and 75 mm (3") tape width

EASY-TO-USE

Quick taping units and tape reels changeovers, manual adjustable side guides and electric switch to start your operations easy and quick

SAFETY FIRST

Pinch points eliminated, central or lateral double emergency buttons, lockable electrical switch and CE compliancy to guarantee ergonomic and safe operations

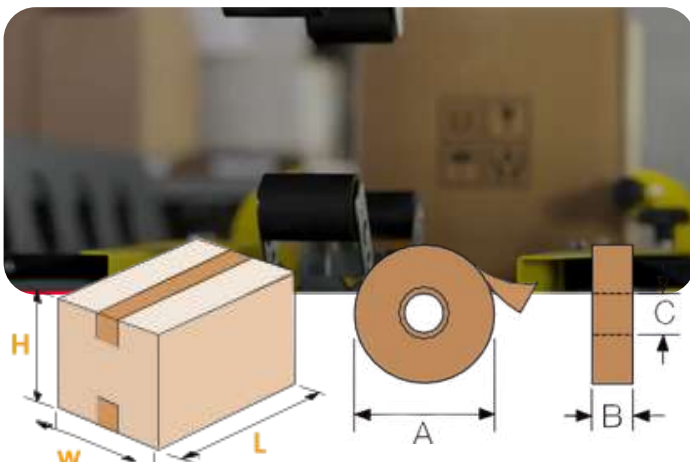

SPECIFICATIONS

Boxes

SK20	
Box Min (mm) LxWxH	150 x 140* x 90**
Box Max (mm) LxWxH	∞ x 500 x 500
SK27	
Box Min (mm) LxWxH	150 x 140* x 90**
Box Max (mm) LxWxH	∞ x 650 x 700
Box Type	RSC, HSC, FEFCO 0200/0201
Flute Type	B-C-E
Min-Max Box Weight (kg)	0,5-32
* 140 with K11, 170 with K12	
** 90 with 30mm leg, 100 with 50mm leg, 120 with 70mm leg	

Machine

Productivity up to (bpm)	20
Based on the shortest processible box length, operator speed, box and tape quality	
Belt Speed (m/min)	22
Operator side	Left - Right
(B) Taping Units	K11 (2"/50mm) – K12 (3"/75mm)
Tape Legs (mm)	30 - 50 - 70
Processable Tapes	PVC / OPP / PET / Paper
(A) Tape Reel Max DIA (mm)	410
(C) Inner Tape Core (mm)	76
Air Consumption (NI/Cycle)	-
(BH) Workbench height (mm)	from 485 to 825
Power Supply	380/415V 50Hz 3PH+N+PE 220/240V 50Hz 1PH+N+PE*
Pneumatic Supply (bar)	-
Installed Power (kW)	0,26
Power Absorption (Amps)	1,08
SK20 - Machine Dimensions LxWxH (mm)	1.080 x 740 x 1.260/1.630
SK27 - Machine Dimensions LxWxH (mm)	1.080 x 1.007 x 1.551/1.891
SK20 - Machine Weight (kg)	140
SK27 - Machine Weight (kg)	200

*Other power supplies available upon request

KEY FEATURES

Perfect Box Traction



Dual top and bottom 75mm drive belts with manually adjustable lower and upper side guides, to guarantee centered and stable box sealing

Easy to Set Up



Fast unit changeover, height adjustment by handles and ON-OFF main electrical switch for an easy and fast start up

Best-in-class Taping Unit



Equipped with SIAT K Taping Units, a market benchmark which offers:

- Smooth and consistent tape application
- Fast reel change and threading

Upscale for Big Boxes



In case of big sized boxes, it is possible to upscale to SK27, reaching up to 650 mm in width and 700mm in height. It is also possible to modify the columns position reaching maximum box height 950mm.

Core Item



To give the best service to our customers, SK20 in its standard configuration is always available in stock

Food Industry



In case of application in food&beverage industries, and in environment with an high rate of corrosion and dispersion of harsh chemicals, it is available in stainless steel AISI 304 as SM2

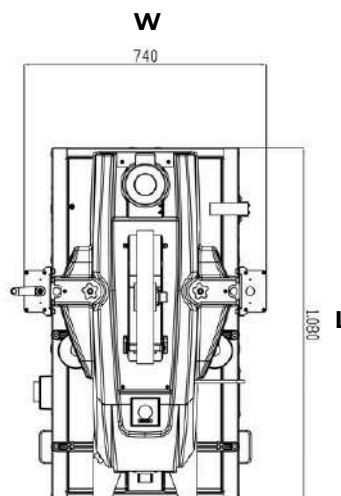
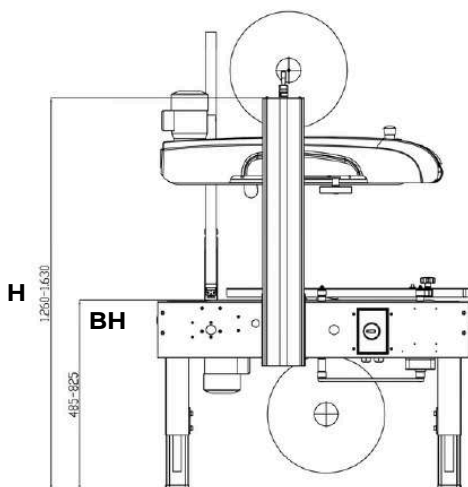

OPTIONALS

Tubular Upper Guides

Energy Saving Mode

High Speed Version (30/min)

Wheels¹

Higher Legs²

Conveyors: GTL- GTR (extendable conveyors), RG (roller conveyor)

¹Workbench height becoming 585-925

²Workbench height becoming 685-1025