

DRIVE BELTS	AUTOMATION GRADE	BOX FORMAT	FORMAT SETTING	SEALING TECHNOLOGY
DUAL ONLY BOTTOM	SEMI-AUTOMATIC	UNIFORM	MANUAL	PSA TAPES

SK10

SEMI-AUTO UNIFORM SIZE CASE SEALER

SK10 is an entry level semi-automatic case sealing machine with double bottom drive belts, designed and engineered by SIAT to seal with adhesive tapes both upper and lower sides of uniform size boxes with manual adjustment, from small to medium dimensions.



KEY BENEFITS

FIRST STEP INTO AUTOMATION

Entry level model with simultaneous upper & lower flaps sealing to overcome manual operations, reaching up to 20 box per minute

LIFETIME QUALITY

Robust Italian design with best-in-class components to guarantee long-lasting heavy duty operations

STABLE BOX SEALING

Dual bottom drive belts with SIAT K taping units available for 50 mm (2") and 75 mm (3") tape width

EASY-TO-USE

Quick taping units and tape reels changeovers, manual adjustable side guides and electric switch to start your operations easy and quick

SAFETY FIRST

Pinch points eliminated, central emergency buttons and CE compliancy to guarantee ergonomic and safe operations

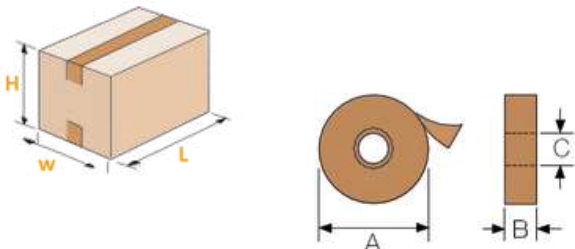

SPECIFICATIONS

Boxes

SK10	
Box Min (mm) LxWxH	150 x 140* x 90**
Box Max (mm) LxWxH	∞ x 500 x 500
Box Type	RSC, HSC, FEFCO 0200/0201
Flute Type	B-C-E
Min-Max Box Weight (kg)	0,5-30
* 140 with K11, 170 with K12	
** 90 with 30mm leg, 100 with 50mm leg, 120 with 70mm leg	

Machine

Productivity up to (bpm)	20
Based on the shortest processible box length, operator speed, box and tape quality	
Belt Speed (m/min)	22
Operator side	Left - Right
(B) Taping Units	K11 (2"/50mm) – K12 (3"/75mm)
Tape Legs (mm)	30 - 50 - 70
Processable Tapes	PVC / OPP / PET / Paper
(A) Tape Reel Max DIA (mm)	410
(C) Inner Tape Core (mm)	76
Air Consumption (NI/Cycle)	-
(BH) Workbench height (mm)	from 485 to 825
Power Supply	380/415V 50Hz 3PH+N+PE 220/240V 50Hz 1PH+N+PE*
Pneumatic Supply (bar)	-
Installed Power (kW)	0,13
Power Absorption (Amps)	1,54
SK10 - Machine Dimensions LxWxH (mm)	1.080 x 690 x 1.170/1.510
Machine Weight (kg)	130
*Other power supplies available upon request	

KEY FEATURES

Perfect Box Traction



Dual only bottom 75mm drive belts with manually adjustable side guide to guarantee centered and stable box sealing

Easy to Set Up



Fast unit changeover, height adjustment by handles and ON-OFF main electrical switch for an easy and fast start up

Best-in-class Taping Unit



Equipped with SIAT K Taping Units, a market benchmark which offers:

- Smooth and consistent tape application
- Fast reel change and threading

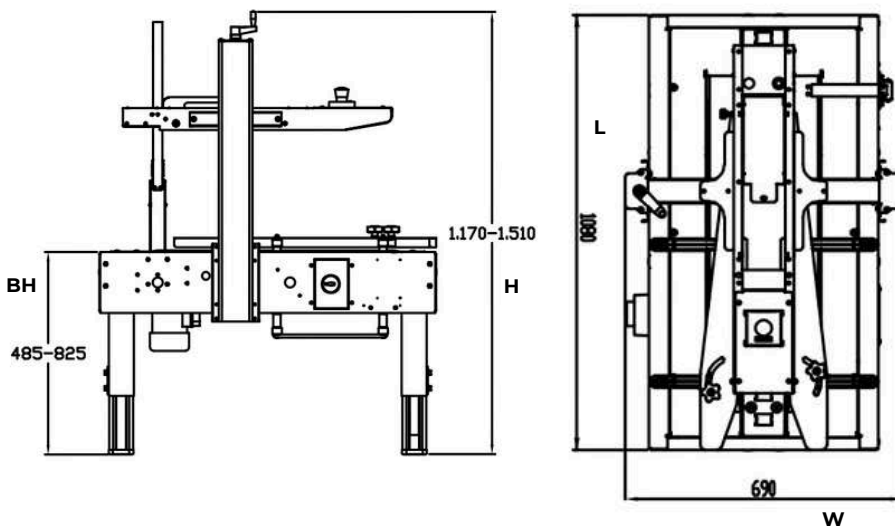

OPTIONALS

Wheels ¹
Higher Legs ²
Conveyors: GTI- GTR (extendable conveyors), RG (roller conveyor)
Roller Upper Guides
¹ Workbench height becoming 585-925
² Workbench height becoming 685-1025