

DRIVE BELTS	AUTOMATION GRADE	BOX FORMAT	FORMAT SETTING	SEALING TECHNOLOGY
SIDE	SEMI-AUTOMATIC	UNIFORM	MANUAL	PSA TAPES

S8

SEMI-AUTO UNIFORM SIZE CASE SEALER



The S8 is an entry-level semi-automatic case sealing machine with side drive belts, designed and manufactured by SIAT to seal both the top and bottom of uniform-sized boxes with adhesive tape, featuring manual adjustment. These machines are a best-seller in SIAT's range, ideal for companies starting their automation journey and requiring a readily available solution. The S8/4 version is specifically designed to handle very small boxes, offering additional flexibility.

KEY BENEFITS

PRODUCTION GUARANTEED

Easy and fast manual box adjustment with simultaneous upper & lower flaps sealing to overcome manual operations, reaching up to 20 box per minute

LIMITED FOOTPRINT

Strong structure and reliable processes embedded in a small machine with limited footprint.

PERFECT BOX SEALING

Dual 50mm side drive belts with SIAT K taping units available in 50mm, ensuring unmatched taping precision and sealing excellence.

EASY-TO-USE

Fast taping units and tape reels changeover, manually adjustable side belts and electric switch to start the working cycles easy and quick

SPECIFICATIONS

Boxes

	S8 - Standard Box Version	S8/4 - Small Box Version
Box Min (mm) LxWxH	150 x 150 x 120	150 x 105 x 90
Box Max (mm) LxWxH	∞ x 500 x 500	∞ x 500 x 500

Box Type	RSC, HSC, FEFCO 0200/0201
Flute Type	B-C-E
Min-Max Box Weight (kg)	0,5-32

Machine

Productivity up to (bpm)	20
Based on the shortest processible box length, operator speed, box and tape quality	
Belt Speed (m/min)	22
Operator side	Left
(B) Taping Units	K11 (2"/50mm)
Tape Legs (mm)	30 (S8/4) - 70 (S8)
Processable Tapes	PVC / OPP / PET / Paper
(A) Tape Reel Max DIA (mm)	410
(C) Inner Tape Core (mm)	76
(BH) Workbench height (mm)	from 485 to 825
Power Supply	380/415V 50hZ 3PH + N + PE
Installed Power (kW)	0,18
Power Absorption (Amps)	I
Machine Dimensions LxWxH (mm)	975 x 918 x 1.202 - 1.542 (max)
Machine Weight (kg)	130

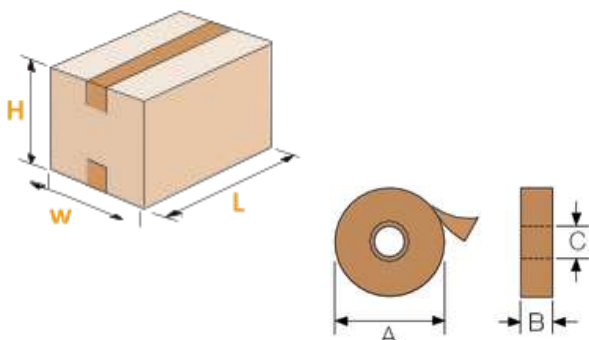

KEY FEATURES

Perfect Box Traction



Dual side 50 mm drive belts manually adjustable to guarantee centered and stable box sealing

Easy to Set Up & Operate



Fast unit changeover, height adjustment by handles and ON-OFF main electrical switch for an easy and fast start up

Best-in-class Taping Units



Equipped with SIAT K Taping Units, the market standard for:

- Smooth, consistent tape application
- Quick reel change and threading

For the Tiniest of Boxes



Ability to process very small and narrow boxes thanks to Integrated Top Taping Unit which allows to further reduce both width and height

Designed for Durability



Built to last, with machines over 30 years old still running smoothly worldwide, Made in Italy with high-quality components

Core Item



To give the best service to our customers, S8 and S8/4 are always available

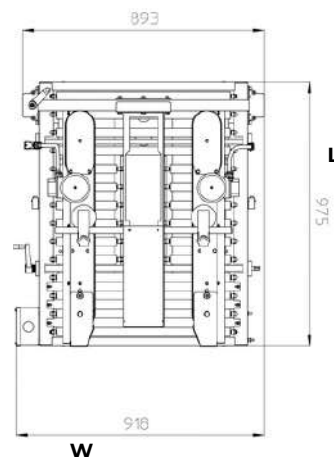
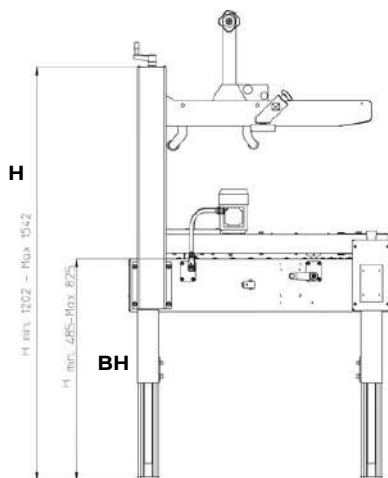

OPTIONS

Casters/Wheels¹

Higher Legs²

Conveyors: GTL- GTR (extendable conveyors), RG (roller conveyor)

¹Workbench height becoming 585-925

²Workbench height becoming 685-1025