



WL34

Wheel Loader

The ideal entry-level model

Low profile design, outstanding economic efficiency and maximum performance in loading and transporting are key benefits of the WL34 wheel loader. It is the ideal entry-level model in the compact class with 0,6 m3 bucket capacity. It combines power, reliable hydraulics and compact dimensions with sophisticated technology and a convincing price-performance ratio. A durable tool that efficiently manages a high workload.



Highlights

- Maximum traction thanks to articulated pendulum joint
- High-quality powder coating
- 100 % connectible differential lock
- Perfectly tuned kinematics
- Easy entry and exit

Technical Data

Standard engine data

Engine manufacturer	Deutz
Motor type	TD 2.9 L4 S5
Cylinder	4
Drive output	45 kW
Drive output	61 PS
at max. rpm	2,300 U/min
Cylinder capacity	2,900 cm ³
Type of coolant	Water
Exhaust standard level	V
Exhaust aftertreatment	DOC / DPF
Average sound power level LwA (operator's canopy)	98.5 dB(A)
Guaranteed sound power level LwA (operator's canopy)	99 dB(A)
Specified sound pressure level LpA (operator's canopy)	85 dB(A)
Average sound power level LwA (cabin)	98.5 dB(A)
Guaranteed sound power level LwA (cabin)	99 dB(A)
Specified sound pressure level LpA (cabin)	77 dB(A)

Engine data Option 1

Engine manufacturer	Deutz
---------------------	-------

Motor type	TCD 2.9 L4 S5
Cylinder	4
Drive output	55.4 kW
Drive output	75 PS
at max. rpm	2,300 U/min
Cylinder capacity	2,900 cm ³
Type of coolant	Water/charge air
Exhaust standard level	V
Exhaust aftertreatment	DOC/DPF
Average sound power level LwA (operator's canopy)	100.1 dB(A)
Guaranteed sound power level LwA (operator's canopy)	101 dB(A)
Specified sound pressure level LpA (operator's canopy)	85 dB(A)
Average sound power level LwA (cabin)	100.1 dB(A)
Guaranteed sound power level LwA (cabin)	101 dB(A)
Specified sound pressure level LpA (cabin)	78 dB(A)

Electrical system

Operating voltage	12 V
Battery	100 Ah
Alternator	95 A

■ Weights

Bucket capacity (standard bucket)	0.62 m ³
Operating weight	3,900 kg
Tipping load with bucket – machine straight, loading frame horizontal	2,925 - 3,055 kg
Tipping load with bucket – machine pivoted, loading frame horizontal	2,443 - 2,539 kg
Tipping load with pallet fork – machine straight, loading frame horizontal	2,615 - 2,716 kg
Tipping load with pallet fork – machine pivoted, loading frame horizontal	2,200 - 2,276 kg

■ Driver's cab

Driver's cab	FSD (cabin)
--------------	-------------

■ Filling levels

Tank capacity for fuel	65 l
Tank capacity for hydraulic oil	50 l

■ Drive system

Type of drive	Hydrostatic
drive unit	universal joint shaft
Speed levels	2
Axle	PA 1200
Travel speed Standard	0-20 km/h
Travel speed Option 1	0-28 km/h

Operating brake	Hydrostatic drive system acting on all 4 wheels (wear-free)
Parking brake	Service and parking brake in the drive train acts on all 4 wheels
Differential lock	100% (front axle + rear axle)

■ Hydraulic system

Drive hydraulics working pressure (max.)	450 bar
Work hydraulics discharge volume (max.)	57,5 (73,6) l/min
Work hydraulics working pressure (max.)	210 bar

■ Kinematics

Kinematics type	PZ
Lifting cylinder	2
Tipping cylinder	1
Quick change system	hydraulic

■ Steering

Steering type	hydraulically activated articulated pendulum steering
Steering cylinder	1
Oscillating angle	±12 degree

■ Other information

FSD = overhead guard
DPF = diesel particulate filter
DOC = diesel oxidation catalyst
SCR = selective catalytic reduction
Tipping load calculation pursuant to ISO 14397



ETOP
creat să reziste

Republica Moldova, MD-2023
mun. Chișinău, str. Uzinelor 90
+ /373/ 67 707 707
office@etop.md
www.etop.md

Dimensions

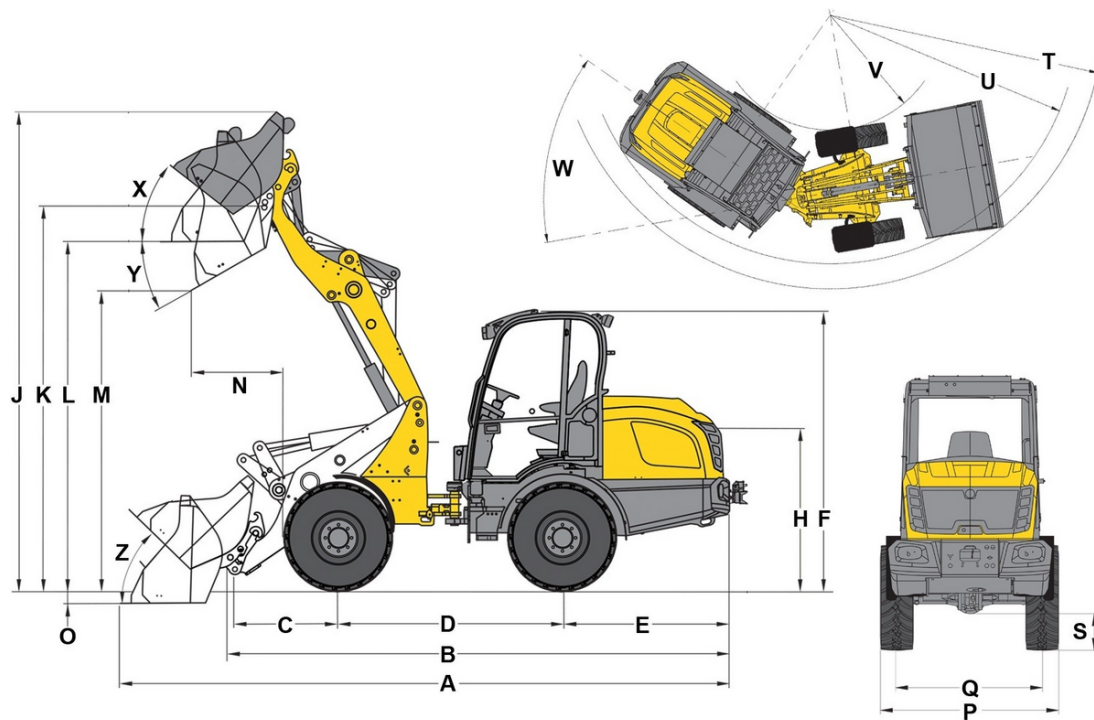

A	Total length	5,010 mm
B	Total length without bucket	4,260 mm
C	Bucket pivot point (to center of axle)	675 mm
D	Wheel base	2,045 mm
E	Rear overhang	1,430 mm
F	Height with lowered operator's canopy	2,220 mm
	Height with operator's canopy raised	2,380 mm
F	Height with cab lowered	2,220 mm
	Height with cab raised	2,420 mm
H	Seat height	1,270 mm
J	Total working height	3,930 mm
K	Bucket pivot point (max. lift height)	3,270 mm
L	Load-over height	2,970 mm
M	Dumping height	2,460 mm
N	Reach (at M)	142 mm
O	Digging depth	43 mm
P	Total width	1,550 mm
Q	Track width	1,260 mm
S	Ground clearance	320 mm
T	Maximum external radius	3,610 mm
U	Radius on the outer edge	3,350 mm
V	Inner radius	1,680 mm
W	Articulation angle	45 °
X	Rollback angle at max. lift height	49 °
Y	Dumping angle	43 °
Z	Rollback angle on ground	43 °



ETOP
creat să reziste

Republica Moldova, MD-2023
mun. Chișinău, str. Uzinelor 90
+ /373/ 67 707 707
office@etop.md
www.etop.md