



WL60

Wheel Loader

High productivity and ideal comfort

The WL 60 wheel loader offers an extremely comfortable cab and a wide variety of options. The operating philosophy is designed for ergonomics. Everything is well within the operator's reach, which ensures fatigue-free work even over a longer period of time. The high flow load-sensing performance hydraulics with 150 l/min flow rate is the strongest in the 6 t class, also ensuring more operating comfort and less fuel consumption by the machine.



Highlights

- {30/40 km/h}{18.64/24.85 mph} speed
- The wheel loader as an attachment carrier
- Clear 3.5-inch digital display
- Comfortable working environment
- Joystick console spring-mounted on the operator's seat

Technical Data

Standard engine data

Engine manufacturer	Perkins
Motor type	904J-E36TA
Cylinder	4
Drive output	74.4 kW
Drive output	101.2 PS
at max. rpm	2,200 U/min
Cylinder capacity	3,621 cm ³
Type of coolant	Water/charge air
Exhaust standard level	V
Exhaust aftertreatment	DOC/DPF/SCR

Electrical system

Operating voltage	12 V
Battery	135 Ah
Alternator	85 A

Weights

Bucket capacity (standard bucket)	1.00 m ³
Operating weight	5,930 kg
Tipping load with bucket – machine straight, loading frame horizontal	3,674 kg
Tipping load with bucket – machine pivoted, loading frame horizontal	3,031 kg

Tipping load with pallet fork – machine straight, loading frame horizontal	3,344 kg
--	----------

Tipping load with pallet fork – machine pivoted, loading frame horizontal	2,791 kg
---	----------

Driver's cab

Driver's cab	Cab
--------------	-----

Filling levels

Tank capacity for fuel	105 l
Tank capacity for hydraulic oil	95 l
Tank capacity for urea solution	19 l

Drive system

Type of drive	Hydrostatic
drive unit	universal joint shaft
Speed levels	2
Axle	PA 1422
Travel speed Standard	0-20 km/h
Travel speed Option 1	0-30 km/h
Travel speed Option 2	0-40 km/h
Operating brake	Disc brake (combined with parking brake)
Parking brake	Service and parking brake in the drive train acts on all 4 wheels
Differential lock	100 % front axle + rear axle

■ Hydraulic system

Drive hydraulics working pressure (max.)	445 bar
Work hydraulics discharge volume (max.)	100 (115-150) l/min
Work hydraulics working pressure (max.)	210 bar

■ Kinematics

Kinematics type	Z
Lifting cylinder	2
Tipping cylinder	1
Quick change system	hydraulic

■ Steering

Steering type	hydraulically activated articulated pendulum steering
---------------	---

Steering cylinder	1
Oscillating angle	±12 degree

■ Noise characteristic values

Average sound power level L _{WA} (cabin)	101.6 dB(A)
Guaranteed sound power level L _{WA} (cabin)	103 dB(A)
Specified sound pressure level L _{pA} (cabin)	74 dB(A)

■ Other information

FSD = overhead guard
DPF = diesel particulate filter
DOC = diesel oxidation catalyst
SCR = selective catalytic reduction
Tipping load calculation pursuant to ISO 14397



ETOP
creat să reziste

Republica Moldova, MD-2023
mun. Chișinău, str. Uzinelor 90
+ /373/ 67 707 707
office@etop.md
www.etop.md

Dimensions

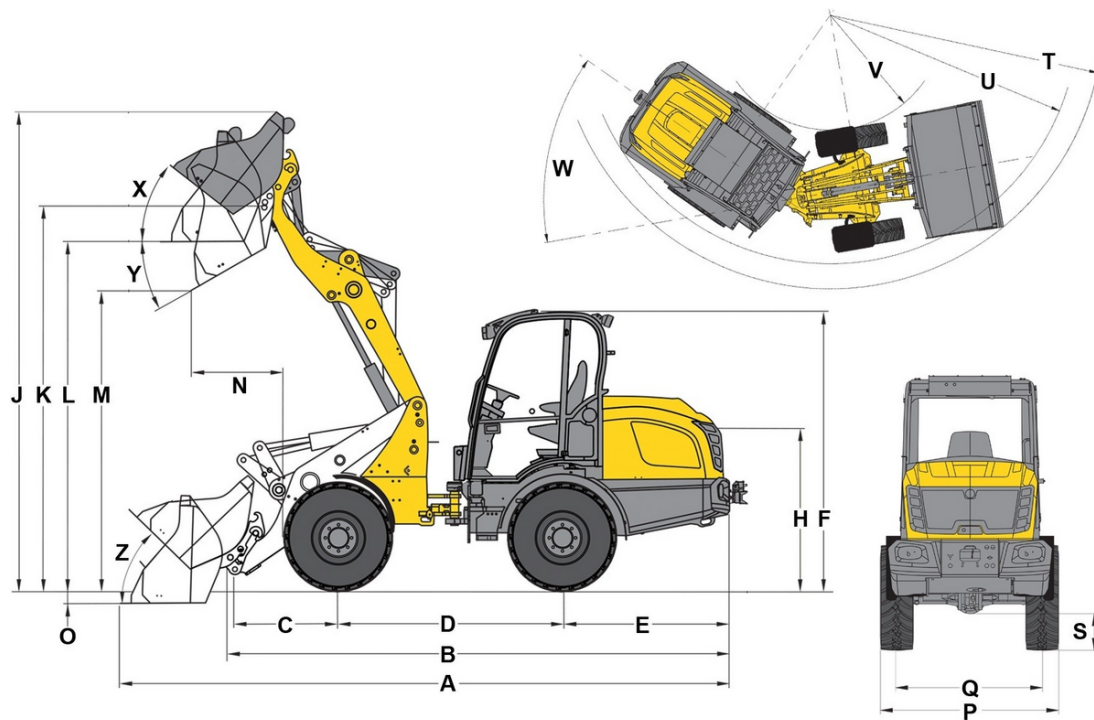

A	Total length	5,898 mm
B	Total length without bucket	4,780 mm
C	Bucket pivot point (to center of axle)	991 mm
D	Wheel base	2,150 mm
E	Rear overhang	1,676 mm
F	Height with cab	2,693 mm
H	Seat height	1,609 mm
J	Total working height	4,409 mm
K	Bucket pivot point (max. lift height)	3,686 mm
L	Load-over height	3,375 mm
M	Dumping height	2,841 mm
N	Reach (at M)	290 mm
O	Digging depth	74 mm
P	Total width	1,829 mm
Q	Track width	1,422 mm
S	Ground clearance	375 mm
T	Maximum external radius	4,072 mm
U	Radius on the outer edge	3,686 mm
V	Inner radius	1,666 mm
W	Articulation angle	42 °
X	Rollback angle at max. lift height	33 °
Y	Dumping angle	33 °
Z	Rollback angle on ground	39 °



ETOP
creat să reziste

Republica Moldova, MD-2023
mun. Chișinău, str. Uzinelor 90
+ /373/ 67 707 707
office@etop.md
www.etop.md