



**WACKER
NEUSON**
all it takes!



DV100

Dual View Dumper

The measure of class and safety.

The powerful engine combined with the high payload (up to 10 tons) combine high material handling with the pulling power it needs. Efficiency utilized to the maximum. And the high safety precautions of the machine such as the entry in signal color, the hill-hold function for mountain travel or the special reversing tone prevent accidents and inattentiveness. This size is a real must-have on the construction site. More power, more bite. With the larger engine, you immediately feel the power during all work and on the road. More tractive force and better acceleration, on any terrain.

Highlights

- Swiveling operator's seat with plenty of legroom
- Seat belt monitoring with start release
- Fold-down armrest for entry and exit from both sides
- 10-ton payload
- Active Sense Control

Technical Data

Hydraulic

Operating pressure hydraulics	240.0 bar
Flow rate	73.0 l/min
Tank capacity	48.0 l

Mechanical - Output Details

Nominal rotation speed	2,300.0 1/min
Travel speed	25.0 km/h

Mechanical Details

Length	4,660.0 mm
Width	2,420.0 mm
Height	3,029.0 mm
Payload	10,000.0 kg
Skip	Front tip skip
Skip capacity levelled	4,150.0 l
Skip capacity heaped	5,000.0 l
Skip capacity waterlevel	2,550.0 l
Pendulum angle	11.0 °
Operating weight (min.-max.)	4,931.0 - 5,132.0 kg

Engine

Cooling	Water-cooling
---------	---------------

Engine type	Diesel engine
Cylinder	4.0
Cylinder capacity	2,924.0 cm ³
Fuel	HVO EN15940
Tank capacity	60.0 l
Effective power	55.4 KW
Nominal Engine speed	2,300.0 1/min
Maximum torque	260.0 Nm
Exhaust-gas limit	EU Stage V
Engine Manufacturer	Deutz
Engine Designation	TD2.9 L4

Environment Data

Sound power LWA, guaranteed	101.0 dB(A)
-----------------------------	-------------

Chassis

Turning radius	6,660.0 mm
Articulation angle	28.0 °
Hydraulik Pump	Axialpistonpump
Flow rate	123.0 l/min

Dimensions

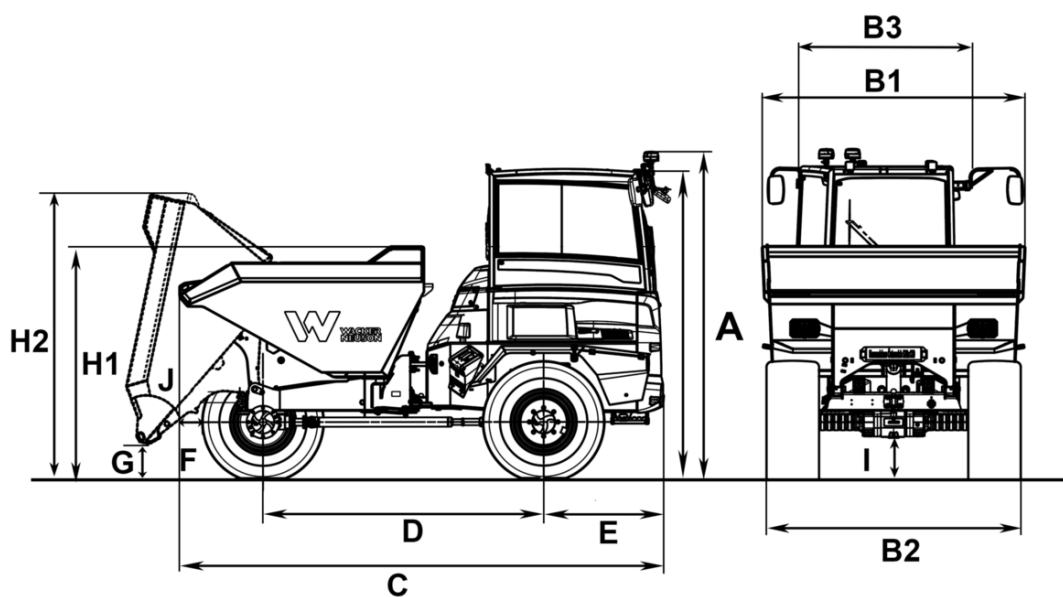

A	Height with cab	2,974 mm
	Height of cab with rotating beacon	3,139 mm
B1	Width of cab	1,731 mm
B2	Width of vehicle	2,420 mm
B3	Width of skip	2,504 mm
C	Total length of cab	4,660 mm
D	Wheel base	2,700 mm
E	Rear overhang	1,157 mm
F	Dumping width	729 mm
G	Dumping height max.	333 mm
H1	Skip height	2,073 mm
H2	Skip height tilted	2,740 mm
I	Ground clearance	390 mm
J	Dumping angle	49 °



ETOP
creat să reziste

Republica Moldova, MD-2023
mun. Chișinău, str. Uzinelor 90
+ /373/ 67 707 707
office@etop.md
www.etop.md