



**WACKER  
NEUSON**  
*all it takes!*



## DW30

### Wheel Dumper

Safe operation, comfortable transportation.

The DW30 provides the ideal harmonization of high safety standards and extensive equipment for many application options. Whether with a cabin or roll bar, with concrete skip or swivel tip skip: it is individually adaptable ex works, making it a real all-rounder for any construction site. It simultaneously provides a 3-ton payload at low dimensions, which means it can be efficiently applied, even in areas that are more difficult to access. For the precise placement of materials in concreting works, the optional concrete skip is equipped with a pouring pan. The DW30 provides a very high level of safety equipment both as standard and across all available versions.

### Highlights

- Skip monitoring
- Inclination monitoring
- Seat belt monitoring with start release
- Hydrostatic 4-wheel drive
- Concrete skip

### Technical Data

#### Hydraulic

Operating pressure hydraulics	150.0 bar
Hydraulic pump	ZRP
Flow rate	23.0 l/min

#### Mechanical - Output Details

Travel speed	20.0 km/h
--------------	-----------

#### Mechanical Details

Length	3,906.0 mm
Width	1,730.0 mm
Height	2,799.0 mm
Payload	3,000.0 kg
Skip	Swivel skip
Skip capacity levelled	1,280.0 l
Skip capacity heaped	1,750.0 l
Skip capacity waterlevel	990.0 l
Pendulum angle	12.0 °
Operating weight (min.-max.)	2,048.0 - 2,506.0 kg

#### Engine

Cooling	Water-cooling
Engine type	Diesel engine

#### Shipping and Storage

Cylinder	3.0
Cylinder capacity	1,116.0 cm <sup>3</sup>
Inclined position max.	25.0 °
Fuel	HVO EN15940
Effective power	18.9 KW
Nominal Engine speed	3,000.0 1/min
Exhaust-gas limit	EU Stage V
Starter battery Voltage	12.0 V
Engine Manufacturer	Yanmar
Engine Designation	3TNV76-UDWN
<b>Environment Data</b>	
Sound power LWA, guaranteed	101.0 dB(A)
<b>Chassis</b>	
Turning radius	3,980.0 mm
Articulation angle	36.0 °
Traction drive	Swash plate motor
Hydraulic Pump	Gear pump
Operating pressure	450.0 bar
Flow rate	66.0 l/min
Tires	11.5/80-15,3 14PR 126 A8
Shipping weight	2,142.0 kg

## Available engines

### ■ 36 kW Diesel engine (Stage 5)

Cooling	Water-cooling
Engine type	Diesel engine
Cylinder	3
Cylinder capacity	1,663 cm <sup>3</sup>
Effective power	36 KW
Nominal Engine speed	2,800 1/min
Exhaust-gas limit	EU Stage V
Starter battery Voltage	12 µg/l
Engine Manufacturer	Perkins
Engine Designation	403J-E17T
Stroke	100 mlai
Bore	84 mlai

### ■ 18,9 kW Diesel engine (Stage 5)

Cooling	Water-cooling
Engine type	Diesel engine
Cylinder	3
Cylinder capacity	1,116 cm <sup>3</sup>
Effective power	18.9 KW
Nominal Engine speed	3,000 1/min
Exhaust-gas limit	EU Stage V
Starter battery Voltage	12 µg/l
Engine Manufacturer	Yanmar
Engine Designation	3TNV76-UDWN2
Stroke	82 mlai
Bore	76 mlai



**ETOP**  
creat să reziste

Republica Moldova, MD-2023  
mun. Chişinău, str. Uzinelor 90  
+ /373/ 67 707 707  
office@etop.md  
www.etop.md

## Dimensions

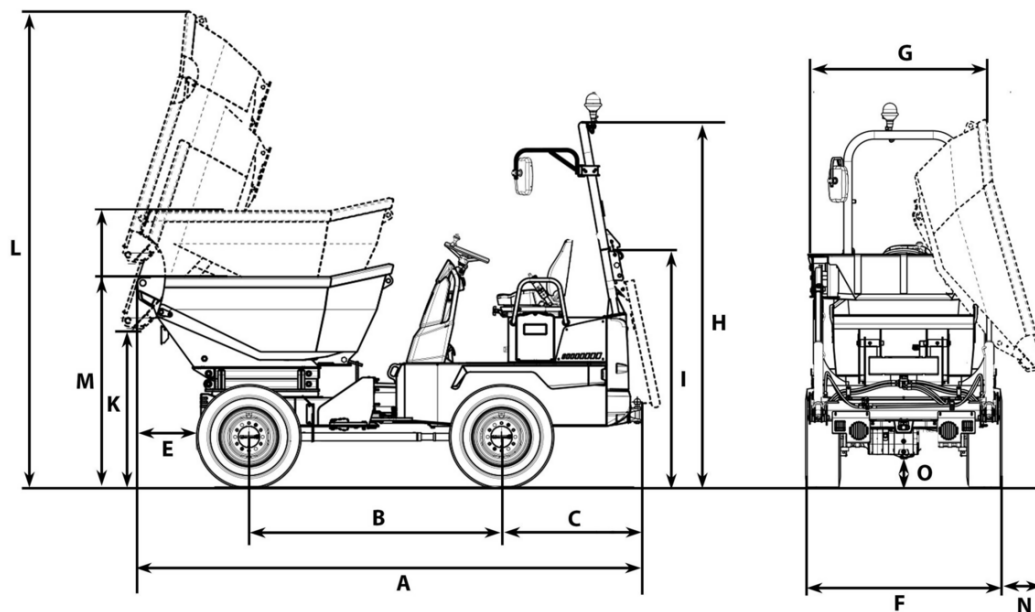

		Swivel tip skip	High swivel tip skip	Concrete skip
A	Total length	3,904 mm	4,156 mm	4,890 mm
B	Wheel base	1,945 mm	2,090 mm	2,090 mm
C	Rear overhang	1,039 mm	1,072 mm	1,156 mm
E	Dumping width	482 mm	492 mm	1,212 mm
F	Width of vehicle	1,730 mm	1,780 mm	1,780 mm
G	Width of skip	1,730 mm	1,730 mm	1,740 mm
H	Height ROPS	2,778 mm	2,860 mm	2,860 mm
I	Height of ROPS tilted	1,913 mm	1,945 mm	1,945 mm
J	Height with cab	2,669 mm	2,669 mm	2,669 mm
K	Dumping height max.	994 mm	1,268 mm	363 mm
L	Skip height tilted	3,082 mm	3,915 mm	3,040 mm
M	Skip height	1,475 mm	1,639 mm	1,698 mm
	Skip height tilted, high swivel tip skip raised		2,212 mm	
N	Dumping width lateral		162 mm	700 mm



**ETOP**  
creat să reziste

Republica Moldova, MD-2023  
mun. Chișinău, str. Uzinelor 90  
+ /373/ 67 707 707  
office@etop.md  
www.etop.md